

SupaChair
SAFARI Sport

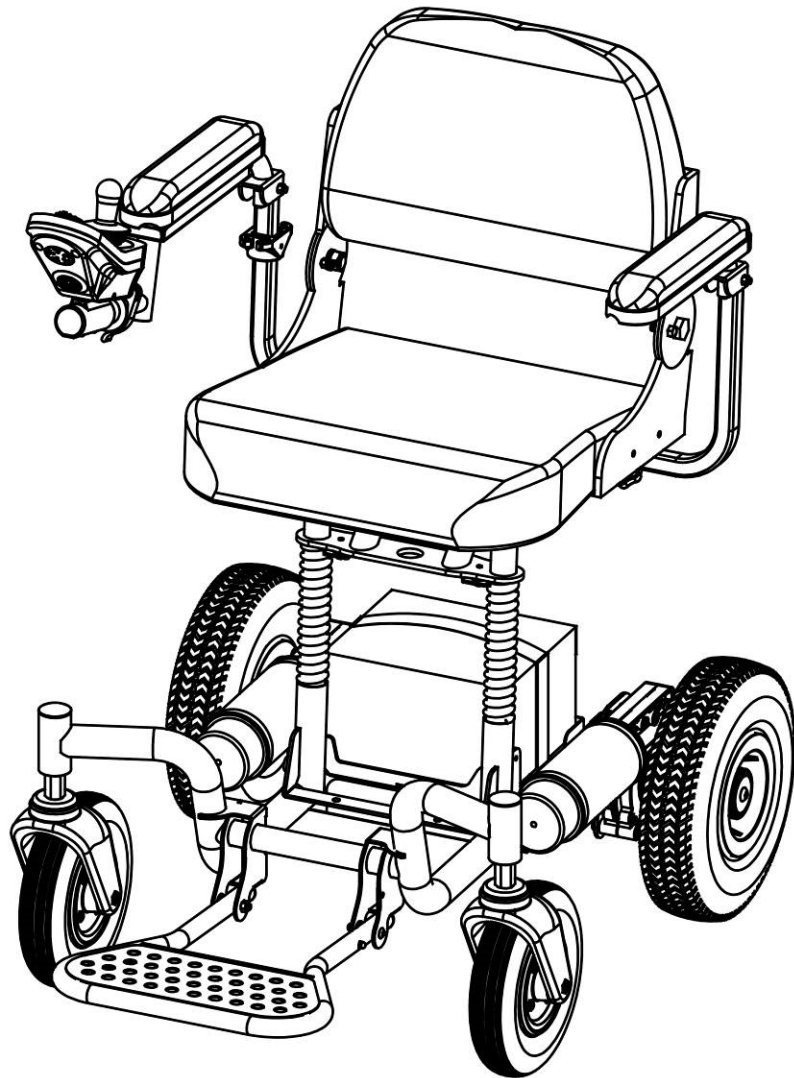

User Manual

You must read this manual before using your Wheelchair



MDSS GmbH
Schiffgraben 41
30175 Hannover, Germany

SupaChair

Distributor:



P/N: 9015926 Rev. 01/20

Table of contents

Contents	Pages
Intended use- - - - -	-2
Safety Symbols, Words and Labels- - - - -	-3
Safety Instructions - - - - -	-4
Electromagnetic Interference - - - - -	-8
Assemble the Seat & Seat Belt - - - - -	-11
Foldable Seat Frame (Optional) - - - - -	11
Assembly of the Wheelchair- - - - -	12
Drive Wheel Release Mechanism- - - - -	-16
Swivel Seat (Optional) - - - - -	-17
Spare Battery Tray (Optional) - - - - -	-18
Joystick for Attendant (Optional) - - - - -	-19
To Swing Away Joystick (Optional) - - - - -	20
The Joystick Control- - - - -	21
Fold the Wheelchair - - - - -	-28
Precaution - - - - -	31
Battery and Charge - - - - -	32
Battery Charger- - - - -	34
Battery Care & Maintenance - - - - -	35
Specifications - - - - -	36
SupaChir Warranty - - - - -	37
Purchaser information - - - - -	38

Manufacturer: EUROGREEN INTERNATIONAL INC.

No.48, Ln. 220, Sec.1, Fuzun Rd, Yuanlin

Township, Changhua County, 51055, TAIWAN

SAVE THIS MANUAL FOR FUTURE REFERENCE.

INTENDED USE

● Intended use of device

The device is a powered wheelchair intended to provide mobility to persons restricted to a sitting position.

As a portable compact electric power chair for indoor or outdoor use. Suitable for people suffering from age related conditions and walking difficulties associated with other health issues.

Especially suitable for indoor use in confined spaces.

● Device description

A rear wheel drive lightweight portable electric wheelchair with seat suspension. This product has been designed to handle robust outdoor conditions as well as negotiating compact areas indoors. Disassembly without tools for transport is quick and easy.

● Technological characteristics

The Supachair Safari series has been designed to overcome the heavy component weights associated with electric power chairs without compromising performance or functionality. This has been achieved with smaller high efficiency motors, lightweight gearboxes, smaller batteries and lightweight materials. Quick disassembly without tools allows for easy transport in smaller vehicles.

SAFETY SYMBOLS, WORDS AND LABELS

What You Need to Know About Safety Instructions

Warning and Important Safety Instructions appeared in this manual are not meant to cover all possible conditions and situations that may occur. Common sense, caution and care must be exercised when operating or cleaning your Supachair.

Always contact your dealer, distributor, service agent or manufacturer about problems or conditions you do not understand.



WARNING indicates a potentially hazardous situation which, if not avoided, could result in death or serious injury.



CAUTION indicates a potentially hazardous situation which, if not avoided, may result in minor or moderate injury.



Radio wave sources may affect motorized vehicle.

SAFETY INSTRUCTIONS



- Please read this manual before using your Wheelchair.
- Check the frame lock and all clamps before using the wheelchair.
- The power switch should be “**Off**” when the user is entering or leaving the chair.
- The Wheelchair was designed for hard and flat surfaces. It should not be used on steep slopes or loose surfaces.
- Reduce speed when turning.
- Use of the wheelchair in wet conditions should be avoided when possible.
- Do not use the Wheelchair on slopes over 8 degrees.
- When the yellow battery light comes on, you should prepare to recharge your battery as soon as possible. If the red battery light comes on or is flashing, you should stop immediately for recharging.
- Always switch the power “**off**” before leaving or while it is unattended.
- Do not put your fingers on the joystick control lever before you turn the key switch on. This could cause the Wheelchair to move without warning.
- Your Power switch must be in the “**off**” position before connecting the battery lead.
- This chair must not be used if the anti-tip wheels have been removed.



- A. ENVIRONMENTAL CONDITIONS WARNING:** The power chair is not designed for use in a heavy rain storm, or in snowy or icy conditions.
- i. Contact with water or excessive moisture can cause an electrical malfunction. The frame, motors and other power chair parts are not water-tight and may rust or corrode from the inside.
To avoid a power chair failure:
 - Minimize exposure of your power chair to a rain storm or very wet conditions.
 - Never take your power chair into a shower, tub, pool or sauna.
 - Do not use your power chair in fresh or salt water (such as at the edge of a stream, lake or ocean).
 - Make sure all electrical connections are secure.
 - ii. Proceed slowly and use extra care if you must operate your power chair on a wet or slick surface.
 - Do so only if you are sure it is safe.
 - Stop if one or both main wheels lose traction. If this occurs, you may lose control of your power chair or fall.
 - Never operate your power chair on a slope or ramp if there is snow, ice, water or oil film present.
 - iii. When not in use, keep your power chair in a clean, dry place.
- B. TERRAIN**
- i. This power chair is designed for use on firm, even surfaces such as concrete, asphalt and indoor flooring.
 - ii. Do not operate your power chair in sand, loose soil or over rough terrain. Doing so may damage wheels, bearings, axles or motors, or loosen fasteners.
- C. STREET USE WARNING:** In most states, power chair are not legal for use on public roads. Be alert to the danger of motor vehicles on roads or in parking lots.
- i. At night, or when it is hard to see, use reflective tape on your power chair and clothing.
 - ii. It may be hard for drivers to see you. Make eye contact with drivers before you proceed. When in doubt, yield until you are sure it is safe.

D. MOTOR VEHICLE SAFETY

- i. Never sit in this power chair while in a moving vehicle. In an accident or sudden stop you may be thrown from the power chair.
- ii. Always move to an approved vehicle seat. You must be secured with proper motor vehicle restraints.
- iii. Never transport this power chair in the front seat of a vehicle. It may shift and interfere with the driver.
- iv. Always secure this power chair so that it cannot roll or shift.

E. TRANSFERS WARNING: It is dangerous to transfer on your own. It requires good balance and agility. Be aware that there is a point during every transfer when the seat is not below you.

To avoid a fall:

- i. Always turn off power before you transfer to or from your power chair. If you fail to do so you may touch the joystick control lever and cause your power chair to move when you do not expect it.
- ii. Make sure power chair is turned "Off". This keeps the power chair from moving when you transfer.
- iii. Move your power chair as close as you can to the seat you are transferring to.
- iv. Transfer as far back onto the seat surface as you can. This will reduce the risk that you will miss the seat or fall.

F. REACHING OR LEANING WARNING: Reaching or leaning affects the center of balance of your power chair. If done improperly, a fall or tip-over is likely. When in doubt, ask for help or use a power chair to extend your reach.

To reduce the risk of injury and/or damage to the power chair:

- i. Never reach or lean if you must shift your weight sideways or rise up off the seat.
- ii. Never reach or lean if you must move forward in your seat to do so. Always keep your buttocks in contact with the backrest.
- iii. Never try to pick up an object from the floor by reaching down between your knees.
- iv. Never reach or lean over the top of the seat back. This may damage the backrest and cause you to fall.
If you must reach or lean; do so at your own risk.
Remember to:

ELECTROMAGNETIC INTERFERENCE



It is very important that you read this information regarding the possible effects of Electromagnetic Interference on your Supachair.

- i. Move your power chair as close as you can to the object you wish to reach.
- ii. Turn off all power to your power chair. If you fail to do so, you may touch the throttle control lever and cause your power chair to move when you do not expect it.

G. DRIVING IN REVERSE WARNING: Use extra care when you drive your power chair in reverse. You may lose control or fall if one of the rear wheels hits an object.

- i. Operate your power chair slowly and at an even speed.
- ii. Stop often and check to make sure your path is clear of obstacles.

H. WEIGHT LIMIT

- i. Never exceed the weight limit of the power chair.
- ii. The power chair is not designed for weight training and is unsafe for use as a seat while weight training. Weight training from the power chair substantially changes the stability of the power chair and may cause tipping.
- iii. Exceeding the weight limit is likely to damage the seat, frame or fasteners and may cause severe injury to you or others from power chair failure.

I. STAIRWAYS AND ESCALATORS WARNING:

The power chair is not designed to travel up or down stairs or escalators. Always use an elevator. **DO NOT** use an escalator to move the power chair between floors. Serious bodily injury may occur. **DO NOT** attempt to move an occupied power chair between floors using a stairway.

This power chair has an immunity of 20 V/m which should protect it from Electromagnetic Interference (EMI) from Radio Wave Sources. These EM waves are invisible and their strength increases as one approaches the source. All electrical conductors act as antennas to the EM signals and to varying degrees, all power wheelchairs and scooters are susceptible to electromagnetic interference (EMI). This interference could result in abnormal, unintentional movement and/or erratic control of the vehicle.

power chair may be susceptible to electromagnetic interference (EMI), which is interfering electromagnetic energy (EM) emitted from sources such as radio stations, TV stations, amateur radio (HAM) transmitters, two-way radios, and cellular phones. The interference (from radio wave sources) can cause the power chair to release its brakes, move by itself, or move in unintended directions. It can also permanently damage the power chair control system. The intensity of the interfering EM energy can be measured in volts per meter (V/m). Each power chair can resist EMI up to certain intensity. This is called its "immunity level." The higher the immunity level, the greater the protection. At this time, current technology is capable of achieving at least a 20 V/m immunity level, which would provide useful protection from the more common sources of radiated EMI.

Because EM energy rapidly becomes more intense as one moves closer to the transmitting antenna (source), the EM fields from hand-held radio wave sources (transceivers) are of special concern. It is possible to unintentionally bring high levels of EM energy very close to the power chair control system while using these devices. Therefore, the warnings listed below are recommended to prevent possible interference with the control system of the power chair, which should reduce the chance of unintended brake release or power chair movement that could result in serious injury.



Do not operate hand-held personal communication devices such as citizens band (CB) radios, or turn ON personal communication devices and cellular phones while the power chair is turned ON.

- 1) Be aware of nearby transmitters, such as radio or TV stations and try to avoid coming close to them.
- 2) If unintended movement or brake release occurs, turn the power chair OFF as soon as it is safe.
- 3) Be aware that adding accessories or components, or modifying the power chair, may make it more susceptible to EMI; and
NOTE: There is no easy way to evaluate their effect on the overall immunity of the power chair.
- 4) Report all incidents of unintended movement or brake release to the distributor listed on the back of this manual, and **Note whether there is a radio wave source of EMI nearby.**

TURN “OFF” YOUR POWER CHAIR AS SOON AS POSSIBLE WHEN EXPERIENCING THE FOLLOWING:

- Unintended or uncontrollable movement.
- Unexpected brake release

● Important Information

- 1) 20 Volts per meter (V/m) is a generally achievable and useful immunity level against interference from radio wave sources (as of May 1994) (the higher the level, the greater the protection);
- 2) This product has an immunity level of following:

Guidance and MANUFACTURER’S declaration – electromagnetic IMMUNITY – for all ME EQUIPMENT and ME SYSTEMS

Guidance and manufacturer’s declaration – electromagnetic immunity			
The [ME EQUIPMENT or ME SYSTEM] is intended for use in the electromagnetic environment specified below. The customer or the user of the [ME EQUIPMENT or ME SYSTEM] should assure that it is used in such an environment.			
IMMUNITY test	IEC 60601 test level	Compliance level	Electromagnetic environment – guidance
Electrostatic discharge (ESD) IEC 61000-4-2	± 6 kV contact ± 8 kV air	± 6 kV contact ± 8 kV air	Floors should be wood, concrete or ceramic tile. If floors are covered with synthetic material, the relative humidity should be at least 30 %.
Electrical fast transient/burst IEC 61000-4-4	± 2 kV for power supply lines ± 1 kV for input/output lines	± 2 kV for power supply lines ± 1 kV for input/output lines	Mains power quality should be that of a typical commercial or hospital environment.
Surge IEC 61000-4-5	± 1 kV line(s) to line(s) ± 2 kV line(s) to earth	± 1 kV line(s) to line(s) ± 2 kV line(s) to earth	Mains power quality should be that of a typical commercial or hospital environment.
Voltage dips, short interruptions and voltage variations on power supply input lines IEC 61000-4-11	<5 % U_T (>95 % dip in U_T) for 0,5 cycle 40 % U_T (60 % dip in U_T) for 5 cycles 70 % U_T (30 % dip in U_T) for 25 cycles <5 % U_T (>95 % dip in U_T) for 5 s	<5 % U_T (>95 % dip in U_T) for 0,5 cycle 40 % U_T (60 % dip in U_T) for 5 cycles 70 % U_T (30 % dip in U_T) for 25 cycles <5 % U_T (>95 % dip in U_T) for 5 s	Mains power quality should be that of a typical commercial or hospital environment. If the user of the [ME EQUIPMENT or ME SYSTEM] requires continued operation during power mains interruptions, it is recommended that the [ME EQUIPMENT or ME SYSTEM] be powered from an uninterruptible power supply or a battery.
Power frequency (50/60 Hz) magnetic field IEC 61000-4-8	3 A/m	3 A/m	Power frequency magnetic fields should be at levels characteristic of a typical location in a typical commercial or hospital environment.
NOTE U_T is the a.c. mains voltage prior to application of the test level.			

ASSEMBLE THE SEAT

Assemble the seat frame in the manner illustrated.

Assemble the seat belt in the manner illustrated. (Optional accessory)

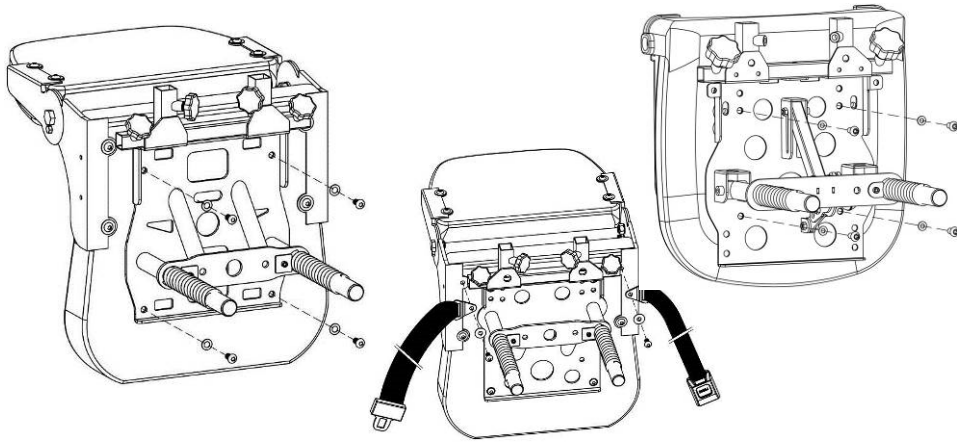

FOLDABLE SEAT FRAME - OPTIONAL

To open the seat frame

Pull out the knob "Z" in the direction of the arrow and lift the seat tube "C" up as illustrated.

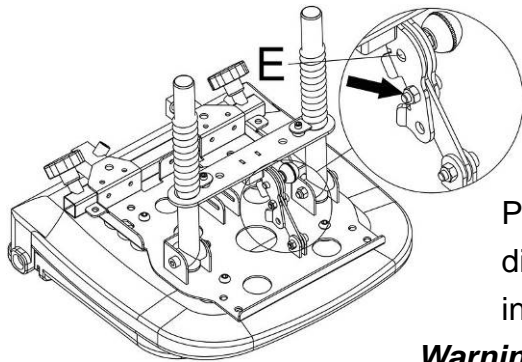
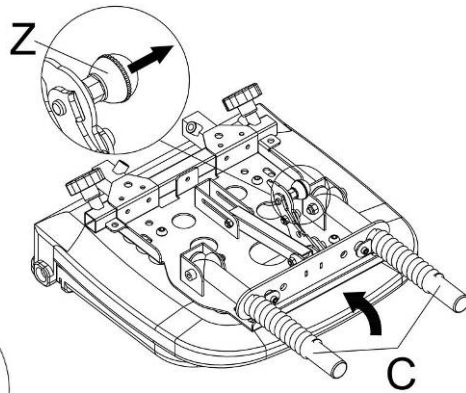

Push the support lever in the direction of the arrow until it clicks into position "E".

Warning: Pin "E" must be locked into the position before use.

To fold the seat frame

Pull out the knob "Z" in the direction of the arrow and push D downward as arrow illustrated then push seat tube "C" downward to fold the seat frame.

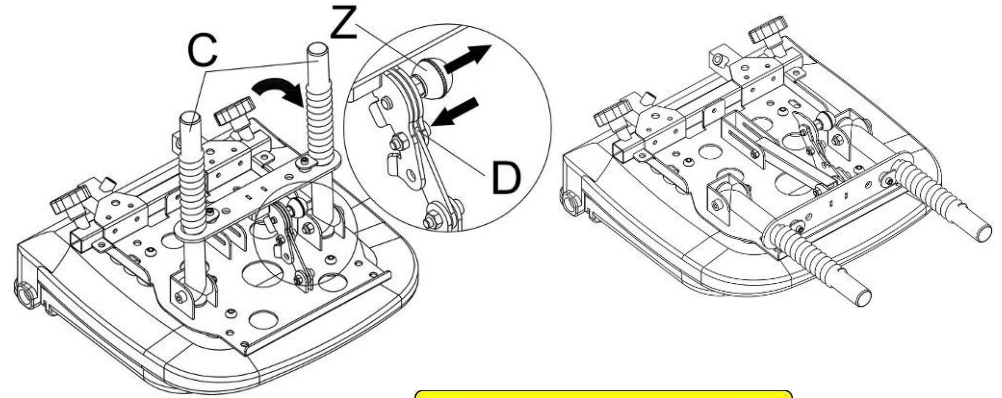

The armrests on your SupaChair are not designed to load bearing.
DO NOT PUT EXCESSIVE WEIGHT ON THE ARMRESTS

ASSEMBLY OF THE WHEELCHAIR

Assemble the anti-tip device

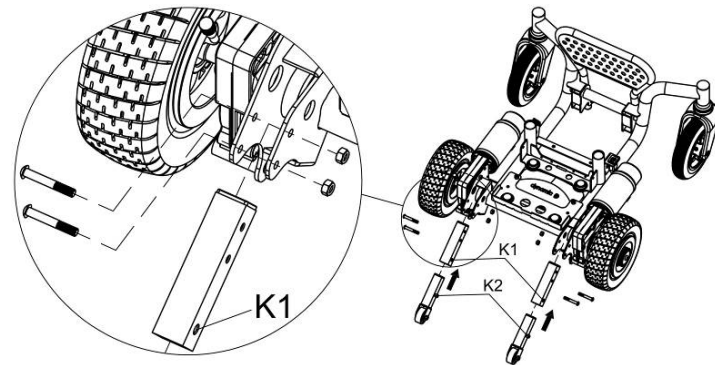

- Push K2 and insert into the corresponding holes as illustrated, you must ensure that K2 has locked into K1.

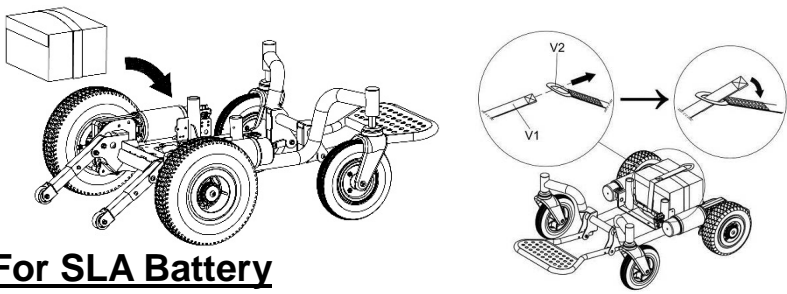

For SLA Battery

Install the battery into the tray and fasten it securely. Tighten the battery strap as illustrated.

For Lithium Battery

- Pull the knob (Z) backward and have 2 block (X) Insert into slots (Y) as illustrated direction then push battery module downward until you hear “click”, the locking into cam locker.
- **You must check that the battery module has locked into position.**

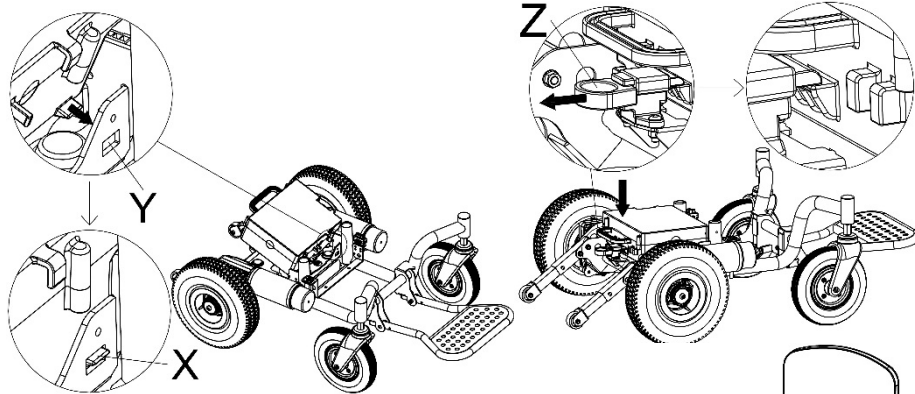
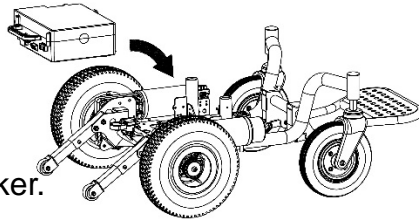

- Open the footrest.
- Fit the seat on to the frame, insert the seat frame tubes into the corresponding holes on the main frame.

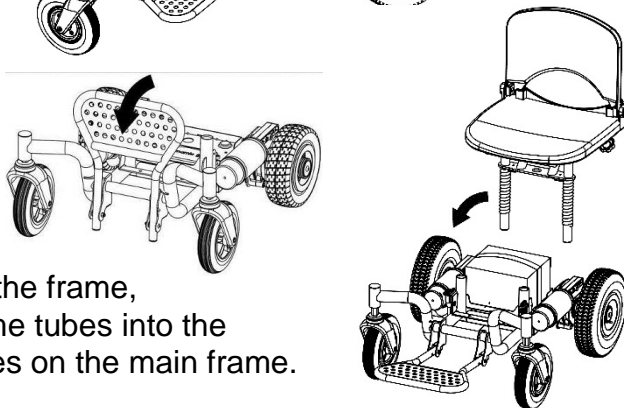

- Insert arm rest per the illustration.
- Tighten the knob.

⚠ WARNING

- This chair must not be used if the anti-tip wheels have been removed.
- insert cable connector **B1** into the corresponding hole of joystick.
- Insert the joystick into the axle of **C**, the groove **S** on the axle must match to pin inside of joystick.
- Tighten clamp **A** correctly and be sure that joystick have securely mounted.
- Plug the cable connector **B2** into the corresponding hole.

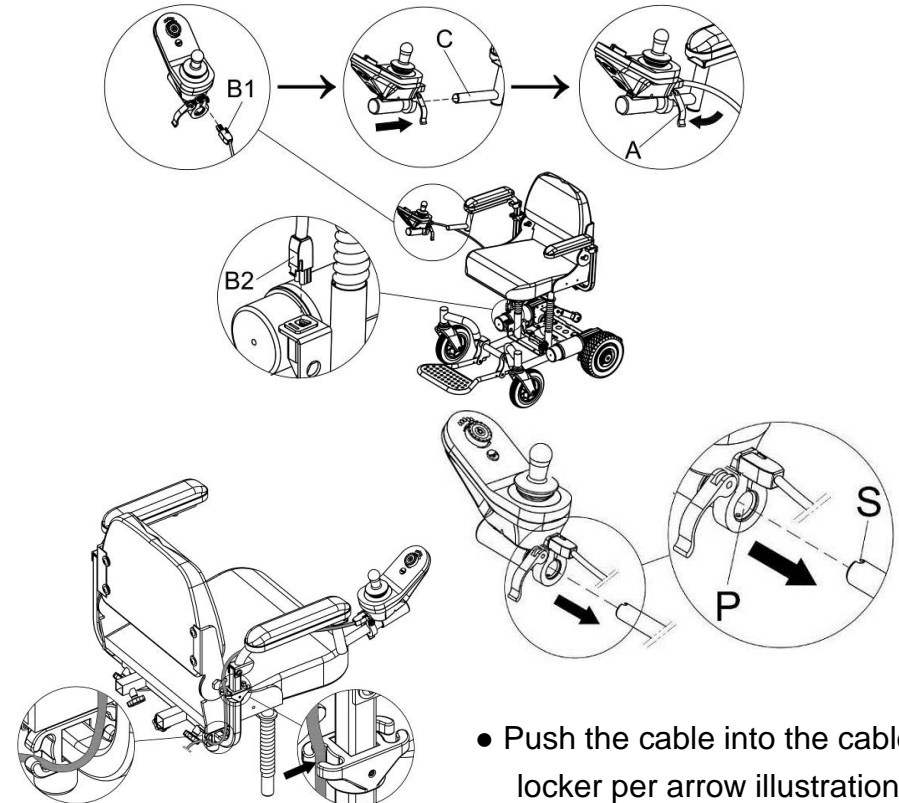
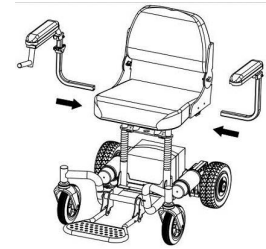

- Push the cable into the cable locker per arrow illustration.

DRIVE WHEEL RELEASE MECHANISM

- This power chair is equipped with a drive wheel release mechanism. Your power chair can be moved manually after the drive wheels are released.

⚠ WARNING

Do not operate this device when on a slope.

To disengage the drive wheels
Pull the drive collar (part “A”) out and
turn it left or right, then release it.

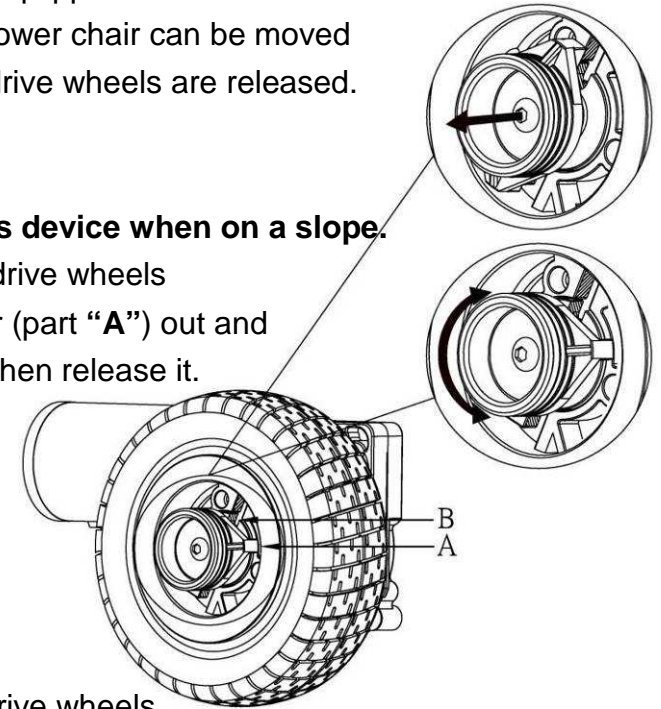

To reconnect the drive wheels

Turn the drive collar (part “A”) until it reconnects to the wheel and
then move the power chair until the collar connects with the drive.
(a loud click)

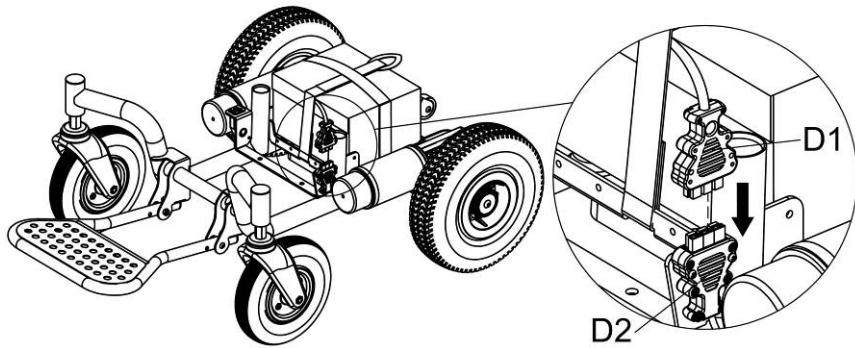
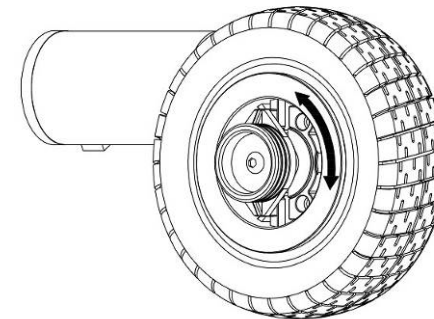

- Plug in the battery connector “D1” into “D2” on the frame.
- The connectors are color matched. Don’t try to force it into the wrong position.
- Inflate the tyres to the maximum of 40 PSI.

The Safari Sport front wheel are fitted with PU formed wheel which do not need to inflate.

⚠ WARNING

IT IS IMPORTANT THAT YOU TAKE EXTRA CARE TO PRACTICE IN AN OPEN SPACE AWAY FROM OBSTRUCTIONS.

⚠ CAUTION

- Do not turn “on” until the user is seated and ready to go.
- Always turn the controller “off” before getting off the scooter.

NOTE: Please be aware that should the power chair wheels hit an obstruction, you may need to help it out manually. Attempting to drive the power chair past an obstruction may result in damage.

- Do not put your hand on the joystick lever when switching “on”.
This way may cause the power chair to move without warning.

SWIVEL SEAT (OPTIONAL)

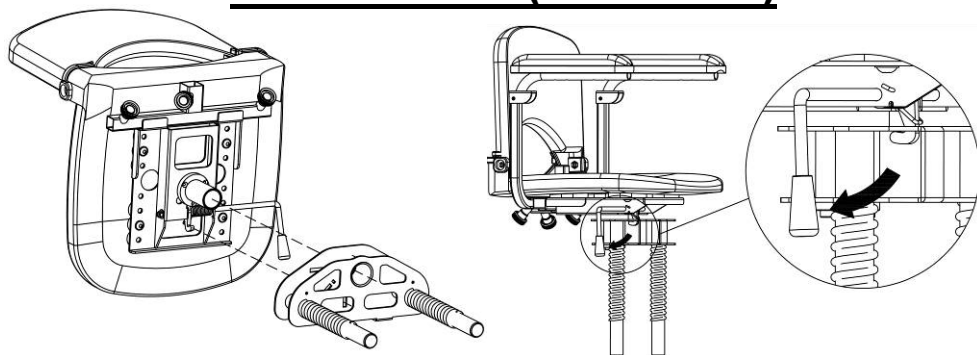

When removing the seat, do not lift the release handle as this could cause the seat support frame to disconnect from the seat and fall.

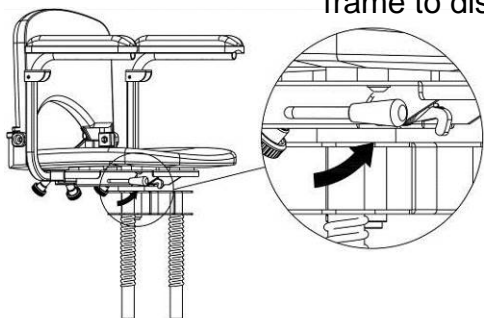

To turn the seat, lift and hold the release handle below the seat (as shown). This will allow the seat to turn.

Hide main cable under the seat frame

Inserting the main cable through swivel seat frame as per arrow illustration is to avoid the main cable / connector breaking when using your power chair.

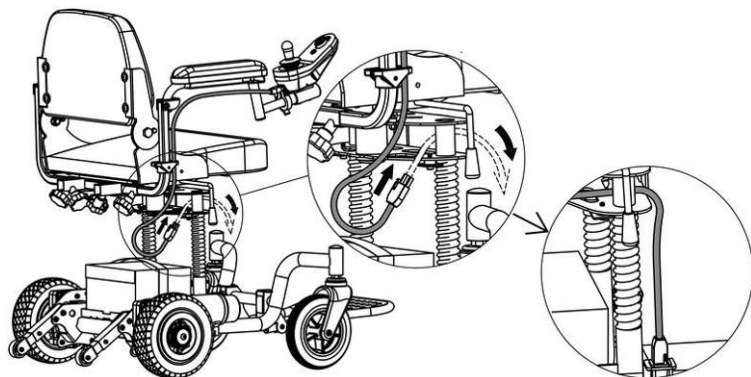

SPARE BATTERY TRAY (OPTIONAL)

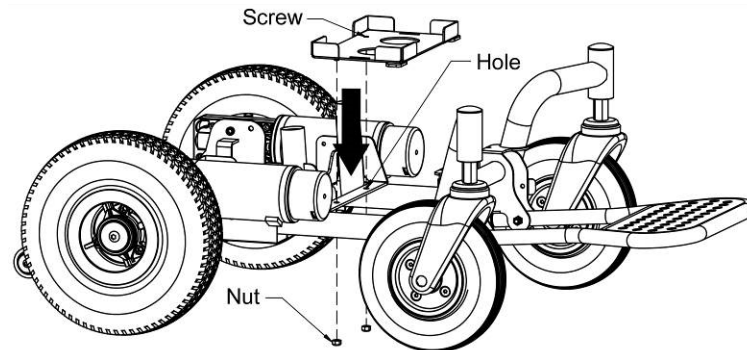

Assemble the battery tray as illustrated. Insert the screws and tighten the nuts.

When using a lithium battery it is recommended that you place your lithium battery on rear tray of the wheelchair and your SLA battery on the front tray.

It is also recommended that you use the lithium battery and keep the SLA battery in reserve.

Tighten the battery strap per illustrated.

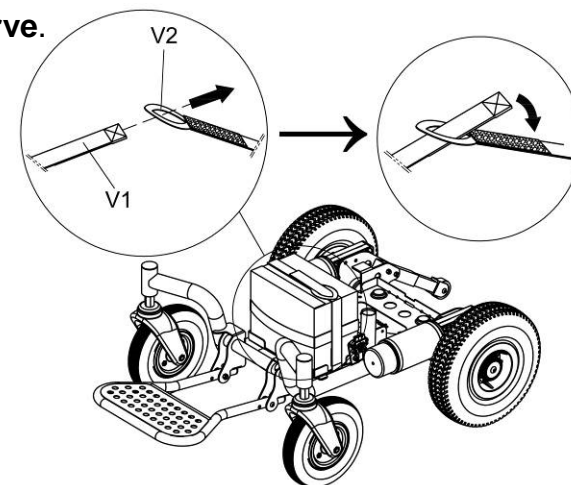

NOTE:

The battery gauge on the wheelchair does not give accurate readings when using a lithium battery and may shut down without warning.

JOYSTICK FOR ATTENDANT (OPTIONAL)

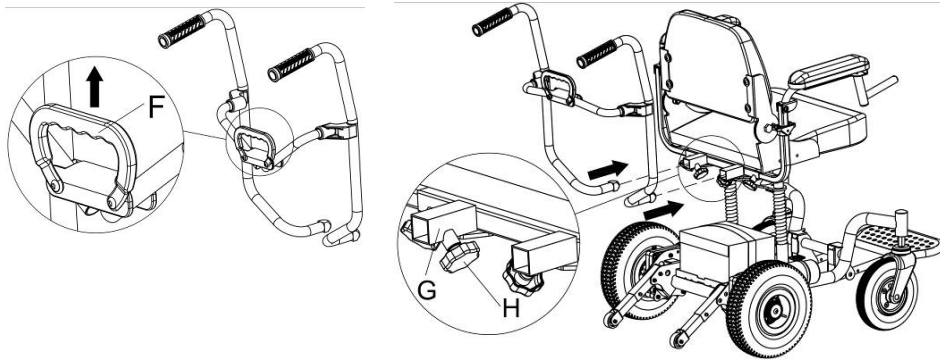

- Pull up the handle **F** as illustrated, and then insert the frame into the holes **G** (under the seat frame) and tighten the knobs **H**.

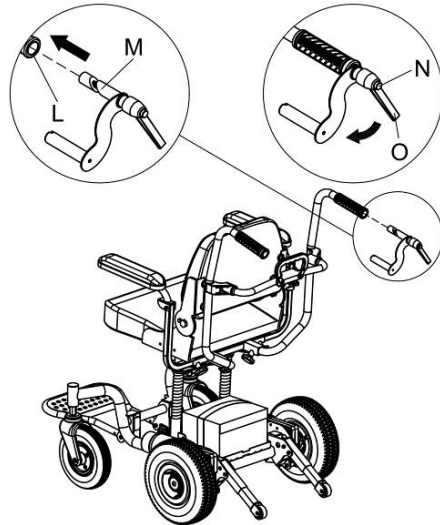

- Insert the cam axle **M** into the handle pipe hole **L** as illustrated and adjust to a comfortable position that is easy to control the joystick, then tighten the screw handle **O** as illustrated. The screw handle can be adjusted by pushing red button **N**.
- Assemble the joystick into the axle pipe **Q**, the groove on the axle must be locked with a pin inside the joystick and then tighten lever as illustrated. Make sure that joystick is securely mounted.
- Plug the cable connector **B2** into the corresponding hole.

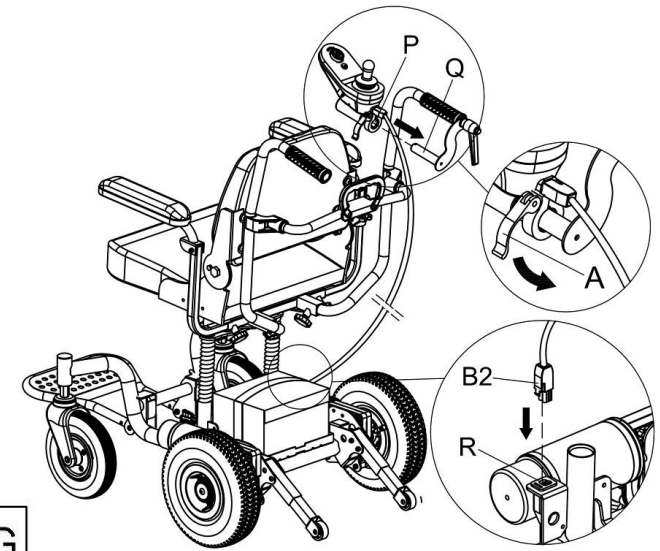

▲ WARNING

- Please be aware that this attendant handle is designed to assemble the Joystick and is not to be used for pushing or pulling the chair under any circumstances.

TO SWING AWAY JOYSTICK (OPTIONAL)

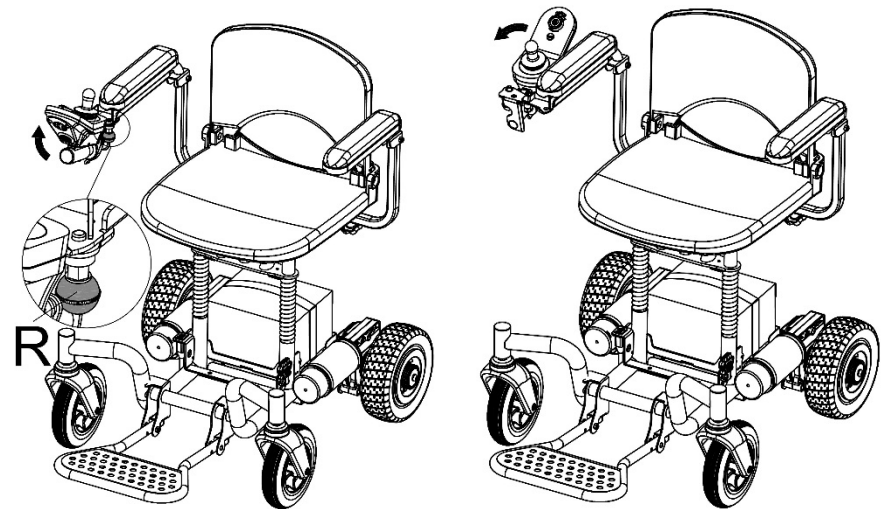

- The joystick can be swung rearwards by pulling the knob "R" and rotating the joystick back alongside the armrest.

THE JOYSTICK CONTROL



• Power up / down



*In the unlikely event that the wheelchair is in a runaway situation, the user can press the Remote's power button to perform an **EMERGENCY STOP**.*



Power OFF

To switch **ON** the System, press the Power button. The Power button is the only user input that can activate the system.

If there is no fault with the system, the Status indicator (through the Power button) will light up green, and the Battery Gauge will display the current battery status.

If there is a fault with the system when powering up, the status indicator will indicate the fault with a series of red flashes. If the fault is one that prevents the system from driving, then the battery gauge will flash continuously.



Power ON

To switch **OFF** the system, press the Power button; the system will power down and the Status indicator will switch off.

The Power button is also used to perform an **EMERGENCY STOP**. The Power button is also used to lock the system.

• Emergency stop

If the user needs to stop the wheelchair quickly, the Power button can be pressed to perform an **EMERGENCY STOP**. The wheelchair will come to a halt quickly; the rate is set by the Emergency Deceleration parameter.

• Drive inhibit indication

Drive inhibit mode is indicated by the battery gauge with a right-to-left chase sequence.

The chase sequence starts with the green LED on the right-hand side, and one-by-one, each LED will switch on and then off. When the sequence completes at the left-most red LED, it begins again at the right-hand side.

The chase sequence continues until the error condition has been cleared.

• OONAPU

OONAPU ("**Out Of Neutral At Power Up**") is a safety feature that prevents accidental movement of the wheelchair, either when powering up, or when the wheelchair comes out of an inhibit state.

If the System is turned on (or comes out of an inhibit state) while the joystick is not in the center position, an OONAPU **warning** is displayed. During an OONAPU warning, the battery gauge LEDs will flash continually to alert the user, and the chair will not drive. If the joystick is returned to the center position within five seconds, the warning will clear and the wheelchair will drive normally.

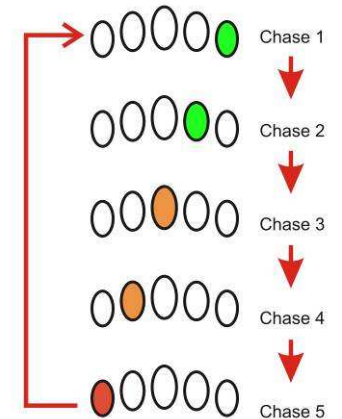

However, if the joystick remains out of neutral for longer than five seconds, an OONAPU **error** will occur; the error is displayed by the Status indicator flashing red, and the chair will not drive. To clear the error, return the joystick to the neutral position and power the unit off and then on again.

- The joystick

The joystick controls the direction and speed of the wheelchair.

When the joystick is deflected from the center position, the wheelchair will move in the direction of the joystick movement.

The speed of the wheelchair is proportional to the joystick deflection, so that the further the joystick is moved from the center position, the faster the wheelchair will travel.



The joystick can also be used to wake up the system when in sleep mode.

- Controlling maximum speed

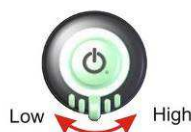

The speed dial

The speed dial allows the user to limit the maximum speed of the wheelchair (that is, the speed when the joystick is fully deflected) to suit their preference and environment.

The dial offers 10 discrete steps between the lowest speed (dial set to the left) and the highest speed (dial set to the right).



As a visual reminder, a speed symbol (shown left) is positioned just below the speed dial to indicate the low and high positions of the speed dial.

The speed symbol

- Stopping distance

Practice riding in an open area free of vehicles, pedestrians and obstacles before using your SupaChair, and learn for stopping distance.

- The horn



The horn button

Press the Horn button to sound the horn. The horn will sound for as long as the Horn button is pressed. The Horn button is also used for unlocking a locked system - see below for more details.

- The lock function

The lock function is used, primarily, to restrict who can use the system, but also can help prevent unintentional use of the controls for when the system is not required for any length of time.

When a system is locked (see below), the system is powered down, and the user controls are not responsive. If the power button is pressed when the system is locked, the locked status is displayed to the user by the Battery Gauge.

To unlock the system, an unlock sequence must be performed (see below) by the user within a specific timeframe. If the sequence is not performed correctly, within the timeframe, the system remains locked.

To **lock** the system, press and hold the Power button for 4 seconds. When entering the locked state, the battery gauge will indicate the transition by flashing LEDs 1, 3, and 5 (far left, middle, and far right) 3 times.



Power OFF



Power ON

To **unlock** the system, press the Power button once, and then, press the Horn button twice — the Horn button must be pressed twice within 10 seconds of pressing the Power button.



If the user implements the unlock sequence incorrectly, or the Power button is pressed again before the unlock sequence is complete, the system will return to the locked state.

During an unlock attempt, the battery gauge will indicate the system is in a Locked state by flashing LEDs 1, 3, and 5 (far left, middle, and far right) until either the system is powered off, unlocked, or the Sequence Timeout is reached.

The lock function is only available when the **Enable Lock** parameter is set to **Yes**;

The horn will not sound when pressing the Horn button during the unlocking sequence.

● The battery gauge

The battery gauge comprises five different LEDs (1 x RED, 2 x AMBER, 2 x GREEN), situated above the Remote's Horn button. The number of LEDs lit depends on the status of the battery, as shown below.



The battery gauge

The battery gauge LEDs are also used to display charging information. See section 7.2 Battery charging for more details.

Normal operation

Battery Gauge	Battery Level	Notes
	Fully charged	This level is set by the Battery Gauge Maximum parameter. Batt Gauge Maximum.
	Consider charging battery	
	Battery needs charging	This level is set by the Battery Gauge Minimum parameter. Battery Gauge Minimum.

Battery gauge operation

This battery gauge is setting based on SLA battery, for lithium battery will need to reprogram for meet with its voltage.

● High voltage warning

A high voltage warning is indicated by all LEDs on, and the green LEDs flashing. This occurs when the battery voltage level has risen above the high voltage warning set-point.

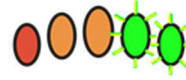

High voltage warning

● Low voltage warning

A low voltage warning is indicated with the left-most LED flashing. This occurs when the battery voltage level has decreased below its low voltage warning set-point.



Low voltage warning

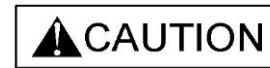

Charge the battery immediately - it is being damaged.

● Cut-off voltage

When the battery voltage decreases below the battery cut-off voltage:



- the status indicator will flash (Flash code 2)
- the first (red) LED will flash on the battery gauge
- the horn will sound once every 10 seconds

The status indicator



The status indicator is located underneath the power button. When the System is not powered up, the status indicator is not lit.



When the System is powered up, and there are no faults with the system, the status indicator will be lit green.



If, when powered up, there is a fault with the system, then the status indicator will flash red. The number of flashes will indicate the type of error.

The status indicator

• Error indication



The status indicator

If there is an error with the system when it is powered up, then the status indicator will flash red; the number of flashes will indicate the type of error.

The table below describes the error indication, and a few possible actions that can be taken to rectify the problem. The actions listed are not in any particular order and are suggestions only; the intention is that one of the suggestions may help you clear the problem. If in doubt, consult your supplier.

Flash	Error description	Possible action
1	Remote / joystick error	Check cables and connectors Replace Remote
2	Network or configuration error	Check cables and connectors Check Bluetooth pairing Reconfigure the system Recharge the battery Check charger Replace modules Contact supplier
3	Left motor error	Check cables and connectors Replace Power Module Check and/or replace left motor
4	Right motor error	Check cables and connectors Replace Power Module Check and/or replace right motor
5	Left park brake error	Check cables and connectors Check left park brake is released
6	Right park brake error	Check cables and connectors Check right park brake is released
7	Module error (other than Remote)	Check cables and connectors Check modules Replace Power Module Recharge battery If the chair stalled, reverse away or remove obstacles, or if the chair was moved while turned off, cycle the power.

The error indicator may continue to flash after an error has been rectified. To clear the error indication, cycle the system's power.

FOLD THE WHEELCHAIR

- Unplug the battery connector **D1**, undo the strap and remove the battery.

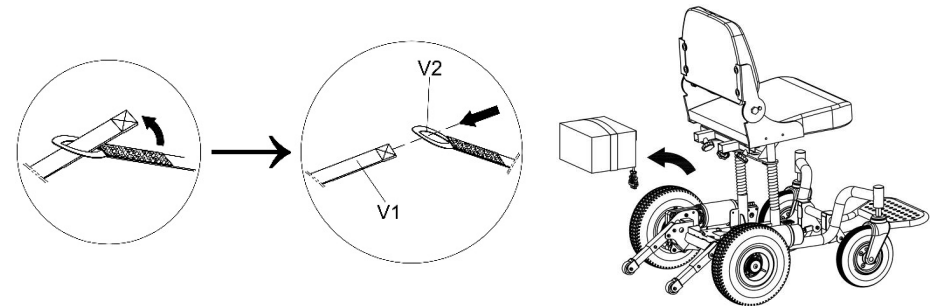
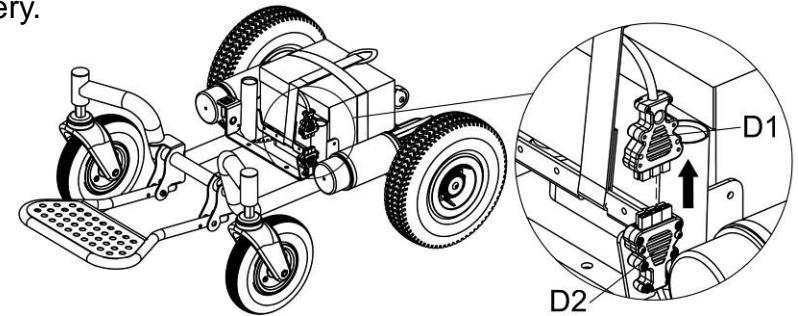

For SLA Battery

- Unplug the battery connector, undo the strap and remove the SLA battery.

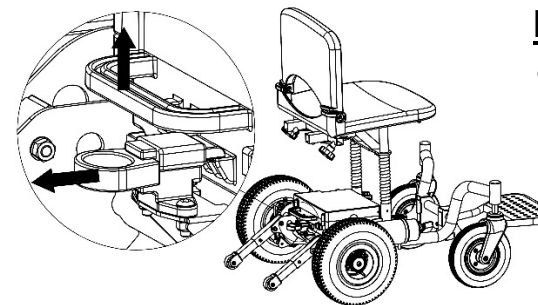

For Lithium Battery

- Unplug the battery connector. Pull knob backward and pull up the battery handle for remove lithium battery as illustrated.

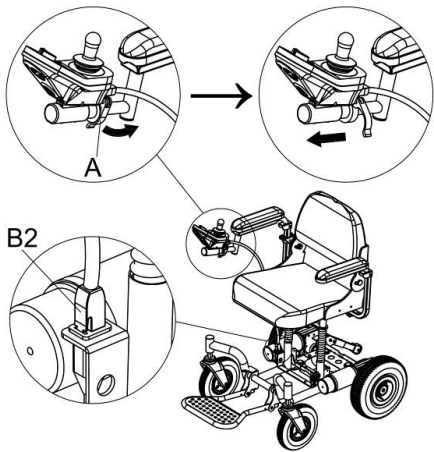

- Loosen clamp **A** and pull out joystick.
- Pull out the cable connector **B2** as indicated. (Refer to P.29)

- Push **X** and pull out the cable for releasing the connector.

CAUTION

Don't try to pull the connector without pushing **X**, this will cause the lock wing **X** to break.

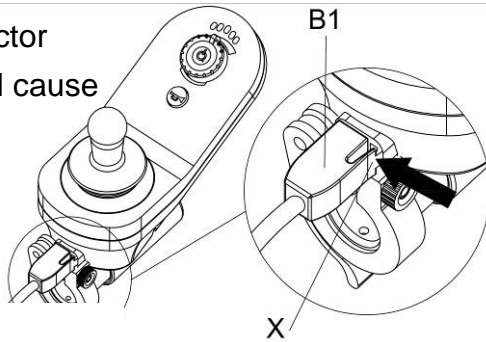

- Pull out the cable from cable locker as arrow illustration.

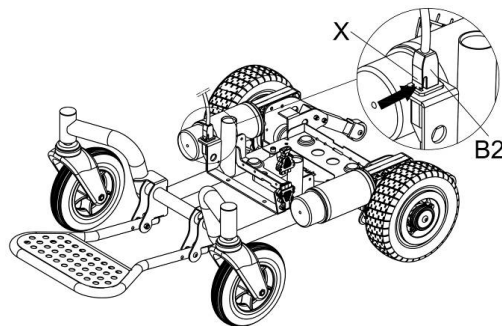
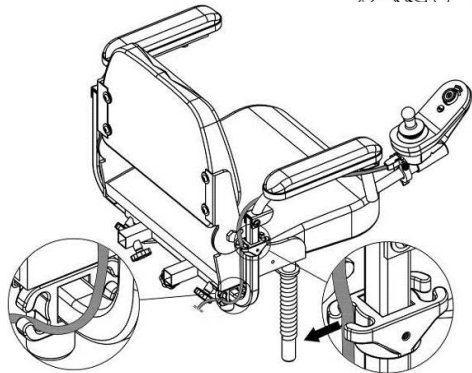

- Release screws and then remove the arm rests from chair.

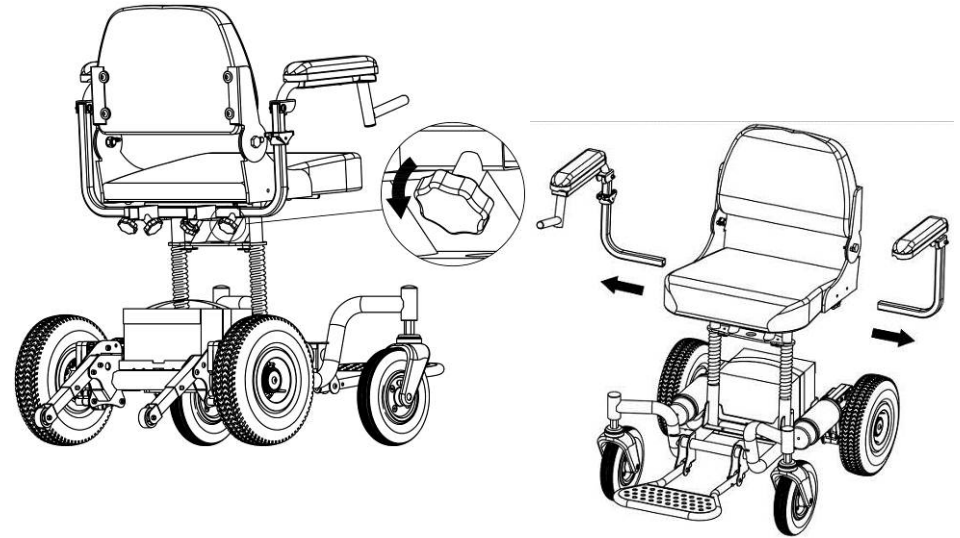

- Remove the seat and fold the footrest.

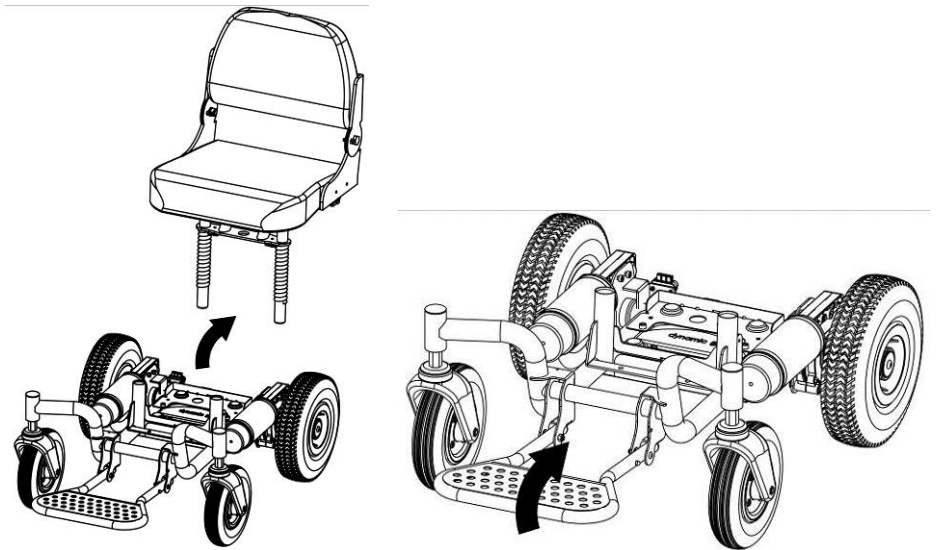

PRECAUTION

- When using your power chair **for the first time you should practice at slow speed in a flat open area** free of obstacles, until you are confident in turning, stopping, reversing and judging braking distance.
- This power chair is designed for the maximum rider weight of **150kgs and for one person use only**.
- Always switch power off (button switch to “Off” position) before leaving your power chair.
- Do not store your power chair outside without adequate protection.
- Keep the shipping carton in dry place after unpacking your power chair in case it needs to be shipping for service.
- This appliance is not intended for use by persons (including children) with insufficiency of physical, sensory or mental capabilities, or lack of experience and knowledge, unless they have been given instructions concerning use of the appliance by a person responsible for their safety. Children should be supervised to ensure that they do not play with the appliance.



Your power chair is extremely maneuverable but sharp turns must only be done at very slow speed.



Avoid power spray water washing of the power chair as this could cause damage to the wire connectors and electronic system. Completely dry off the power chair, if necessary use a dry cloth after cleaning your power chair.

BATTERY AND CHARGE

- When you get your new battery put it on charge for at least 24 hours.
- When recharging your battery, always charge for at least 12 hours or until the light on the charger turns green. It is best to charge for at least another hour after the light turns green.
- Never use the battery for any purpose except to power your chair.
- The battery charger can become hot during charging so your charger should be placed in a suitable place with good air flow and away from children.

To recharge the batteries, follow the steps below:

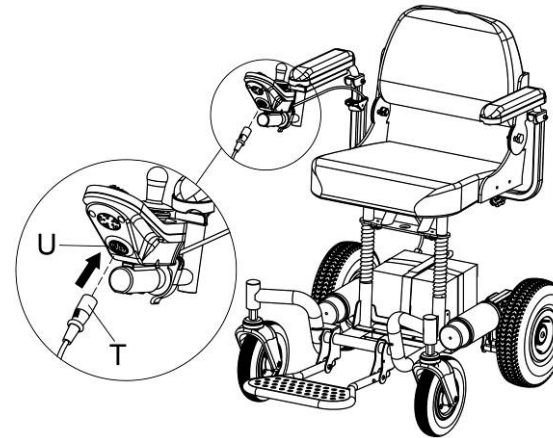

- Place your power chair close to a standard electrical wall outlet.
- Push the power chair switch to the “Off” position.
- Plug the charger power cord (Round plug) into the socket indicated on scooter. (U)
- Plug the charger power plug into a standard wall outlet.
- When charging is completed, the charger’s yellow LED will turn to green.
- Disconnect the charger power cord from the wall outlet and the plug from the power chair when the batteries are fully charged.

Or remove the battery from power chair, and use the connection adaptor. (Optional accessory)
Do not place the battery on a concrete floor for charging. Raise the battery off the concrete with wooden blocks or similar objects.



Battery charging

The battery charging socket of the System is a 3-pin XLR type, located on the Remote (Joystick).

To charge the wheelchair's battery, plug the battery charger into the Remote's XLR socket.

The Battery Gauge will indicate the system is connected to the charger by cycling between a left-to-right chase sequence, and then displaying the approximate battery charge state at the end of the chase sequence.

The system does not have to be powered up when charging the battery, however, if it is not powered up, then the battery gauge will not display the charging state/ chase sequence.

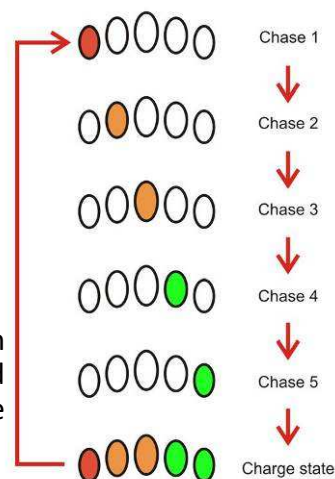

IMPORTANT NOTICE:

The battery terminal covers must be kept in place at all times to avoid the possibility of something falling across the terminals and causing a short circuit. This could damage the battery or even cause it to explode. To dispose of your battery, return it to your dealer or to a recycler. Improper disposal of the battery could result in an explosion causing injury and/or property damage.

Lithium battery & charger are optional accessories.

Travel distance from battery indicator & Cycles life

Battery Type \ Items	Green light	Yellow light	Red light	Cycle life (battery's)
24V SLA Battery	7.5 Km (4.7 miles)	1.5 Km (0.9 miles)		400
24V 15ah Lithium Battery	12 Km (7.4 miles)	2.5 Km (1.6 mile)		1000
24V 12ah Lithium Battery	8 Km (5 miles)	2.5 Km (1.6 miles)		800

NOTE:

Above distances are based on new fully charged batteries with firm even road surfaces, correctly inflated tyres and a 75kg user. When the second Yellow light is "On", you will need to recharge the battery. Do not use power chair when the Red light is ON.

NOTE:

The battery gauge on the power chair does not give accurate readings when using a lithium battery **and may shut down without warning.**

The correct lithium battery indicator can be reprogrammed, check with dealer if lithium battery be used.



BATTERY CHARGER

- Before charging, read the instructions. (included with charger)
- For indoor use only, do not expose to rain.
- Disconnect the mains power supply before making or breaking the connections to the battery.
- This appliance is not intended for persons (including children) with insufficiency of reduced of physical, sensory or mental capabilities, or lack of experience and knowledge, unless they have been given instructions concerning use of the appliance by a person responsible for their safety. Children should be supervised to ensure that they do not play with the appliance.
- This charger is not for recharging non-rechargeable batteries.
- Do not use for charging any batteries which are not specified by the manufacturer.

BATTERY CARE & MAINTENANCE



Important notes to help prolong the life of the battery:

- Before the first use of your battery, put it on charge for 24 hours.
- Do not place the battery on a concrete floor for charging, have the battery raised off the floor on wooden blocks or place the battery on a shelf. (when you move the batteries out of power chair for recharging)
- To fully charge the battery, choose a place where ambient temperature is above 10 degrees Celsius.
- Always recharge your battery as soon as possible after use.
- When yellow light is “On” you should recharge your battery as soon as possible.
- Never use the battery when the red light is “On”. You will discharge the battery below its designated voltage and damage it.
- Do not drop the battery.
- **STORAGE:**
If you know that you will not be use your battery in the near future, disconnect the battery from the charger and store it in a suitable dry place.
Recharge your battery before you use it or **every 3 months (No more than 3 months) if it is not used in that period.**
- Always contact our service agent before you replace the battery or the charger. Using an incompatible battery or charger may damage the power chair and void your warranty.

Specifications

Number of Wheels	4
Front Wheel Size	200mm (8")
Rear Wheel Size	260mm (10")
Ground Clearance	105mm (4.1")
Overall Height / Length	865 mm (34") / 910mm (35.8")
Overall Width	610mm (24")
Seat width x depth	410 x 400 mm (16.2 x 15.8")
Disassembled size: Seat & seat frame Motorize frame	640 x 550 x 550mm (25.2 x 21.7 x 21.7") 750 x 610 x 425mm (29.5 x 24 x 16.7")
Armrest to seat distance	200 mm (7.9")
Backrest height	370 mm (14.6")
Total mass weight	40 Kg (88 lbs) with SLA battery
Weight (dismantled)	Seat & frame : 10.6kg (23.4 lbs) Motorize frame : 20.2kg (44 lbs)
Max Loading	125 kg (275 lbs).
Turn Radius	730mm (28.7")
Transmission	2 x Worm Drive Gearbox
Reverse	Forward/Reverse
Brakes Braking distance	Dynamic Braking & Electromagnetic brake 1 – 1.5 meter
Max Speed SLA Battery	9 kph (5.6 mph)
Battery lithium	24V 12ah or 15ah / 3.2 kg (7 lbs) or 3.7 kg (8.1 lbs)
Battery (SLA)	24V - 15 ah 9.2kg / 20 lbs
Charger (SLA / Lithium)	24 volt 2 amp / 24V 2 amp, off board
In Put AC Voltage Output DC Voltage / Current	AC 100 – 240V 50/60 HZ 24V / 2A
Slope Grade Ability	Maximum Recommended - 8 Degrees.
Travel Distance	Up to 10 km (6.2 mile) with standard SLA battery, Up to 15 Km (9.3 miles) or 11 Km (6.8 miles) with 24V 15ah or 12ah lithium battery. Refer to manual P.34 regarding travel distances
Breaks Down Into	2 pieces

Supachair Warranty

Your SupaChair is fully guaranteed against faults arising due to defects in manufacture or materials as follows

Frame: **2 years**.

All other components except those listed below: **1 year**.

Subject to availability of parts, any such defects will be rectified, either by repair or by unit replacement.

Warranty does not cover

Any damage due to improper use nor the replacement of parts arising from normal wear and tear such as potentiometers, tyres, arm rests and upholstery.

Claims due to a normal increase in operational noise level.

This warranty does not cover labour or service calls.

Batteries

Batteries are covered by a six month warranty from the original manufacturer. Gradual deterioration due to being left in a discharged state or being left in cold conditions for long periods is not covered.

This section MUST BE READ and SIGNED by the purchaser and stamped by the dealer

This warranty record must be kept by the purchaser and a copy supplied with any claim

I / we acknowledge that the SupaChair has been delivered in good order and operating condition and that I / we have been instructed in the care and maintenance, safe operation and proper use of the unit.

Purchasers name.....

Purchase date.....

Address

Serial No

Signature.....

Stamp of Dealer

Date: