

SupaScoota
Motorized vehicle
SPORT (SP-01)

SPORT HD



User Manual

You must read this manual before using your SupaScoota

CE



MDSS GmbH
Schiffgraben 41
30175 Hannover, Germany

SupaScoota

Distributor:



P/N: 903441SPHD

Rev. 01/20

Table of contents

Contents	Pages
Intended use- - - - -	-2
Safety Symbols, Words and Labels- - - - -	-3
Safety Instructions - - - - -	-4
Electromagnetic Interference - - - - -	-8
Assemble the Seat - - - - -	11
Foldable Seat Frame - - - - -	-11
To Open the SupaScoota - - - - -	13
Anti-Tip Wheel- - - - -	-18
Drive Wheel Release Mechanism- - - - -	19
Cruise Control, Lights and Switches - - - - -	20
Auto Switch Off Electronic System- - - - -	-22
Electronic Stability Control (ESC) - - - - -	23
Swivel Seat (Optional) - - - - -	-24
Spare Battery Tray (Optional) - - - - -	-24
Spare Lithium Battery (Optional) - - - - -	-25
Switch the Battery Type - - - - -	-26
Front Wheel Removal (Optional) - - - - -	26
How To Clean the Scooter - - - - -	27
Precaution - - - - -	28
Fold the SupaScoota - - - - -	-28
Charge Battery - - - - -	-32
Battery Charger - - - - -	34
Battery Care & Maintenance - - - - -	35
SLA Battery Wiring Diagram - - - - -	-36
Specifications - - - - -	37
SupaScoota Warranty - - - - -	38
Purchaser information - - - - -	39

Manufacturer: EUROGREEN INTERNATIONAL INC.

No.48, Ln.220, Sec.1, Fuzun Rd, Yuanlin Township,
Changhua County, 51055, TAIWAN

SAVE THIS MANUAL FOR FUTURE REFERENCE.

INTENDED USE

- Intended use of device

As a motorized portable electric vehicle for indoor or outside use by persons with medical conditions require assistance.

- Device description

A battery operated lightweight portable mobility device designed for personal travel indoors and limited outdoor use.

It is used in a sitting position and operated by a hand controlled throttle located on the handle bars. Brake is automatically controlled when releasing the throttle by the electronic controller and magnetic motor brake.

The product is supplied ready to use with a battery and charger and it can be disassembled and folded for transport.

- Technological characteristics

Unique one piece folded frame available in several models to suit different users and applications. The compact design and minimal component weight are of significant benefit to the elderly who are independent and have a need to transport the scooter in their motor vehicle. The electronically controlled speed reduction system which operates when turning is a valuable safety features for elderly users.

SAFETY SYMBOLS, WORDS AND LABELS

What You Need to Know About Safety Instructions

Warning and Important Safety Instructions appeared in this manual are not meant to cover all possible conditions and situations that may occur. Common sense, caution and care must be exercised when operating or cleaning your SupaScoota.

Always contact your dealer, distributor, service agent or manufacturer about problems or conditions you do not understand.



This is the safety alert symbol. It is used to alert you to potential personal injury hazards. Obey all safety messages that follow this symbol to avoid possible injury or death.



WARNING indicates a potentially hazardous situation which, if not avoided, could result in death or serious injury.



CAUTION indicates a potentially hazardous situation which, if not avoided, may result in minor or moderate injury.



Radio wave sources may affect motorized vehicle.

SAFETY INSTRUCTIONS



- Please read this manual before using your SupaScoota.
- Check the frame lock and all clamps before using your SupaScoota.
- Do not turn your Scooter “On” before you are seated ready to go.
- Practice riding in an open area free of vehicles, pedestrians and obstacles before using your SupaScoota near other people. It is also recommended that someone accompanies you during practice.
- The SupaScoota was designed for hard and flat surfaces. It should not be used on steep slopes or loose surfaces
- Reduce speed when turning.
- Take extreme care when driving on wet conditions.
- For your safety, it is recommended that you wear a helmet.
- Do not operate the Forward/Reverse switch when moving. This way could damage your SupaScoota.
- Do not use the SupaScoota on slopes over 8 degrees.
- Do not drive on slopes when the yellow battery light is on. Also, you should recharge your battery as soon as possible. If the red battery light comes on or is flashing, you should stop using immediately and recharge the battery.
- Always switch the power “Off” before leaving your scooter or while it is unattended. You can also disconnect the battery plug before leaving your scooter.
- Do not put your fingers on the Speed Lever before you turn the key switch “On”. This could cause the SupaScoota to move without warning.
- Your key switch must be in the “Off” position before connecting the battery lead.



A. ENVIRONMENTAL CONDITIONS WARNING: The scooter is not designed for use in a heavy rain storm, or in snowy or icy conditions.

- i. Contact with water or excessive moisture can cause an electrical malfunction. The frame, motors and other scooter parts are not water-tight and may rust or corrode from the inside.

To avoid a scooter failure:

- Minimize exposure of your scooter to a rain storm or very wet conditions.
 - Never take your scooter into a shower, tub, pool or sauna.
 - Do not use your scooter in fresh or salt water (such as at the edge of a stream, lake or ocean).
 - Make sure all electrical connections are secure.
- ii. Proceed slowly and use extra care if you must operate your scooter on a wet or slick surface.
 - Do so only if you are sure it is safe.
 - Stop if one or both main wheels lose traction. If this occurs, you may lose control of your scooter or fall.
 - Never operate your scooter on a slope or ramp if there is snow, ice, water or oil film present.
 - iii. When not in use, keep your scooter in a clean, dry place.

B. TERRAIN

- i. This scooter is designed for use on firm, even surfaces such as concrete, asphalt and indoor flooring.
- ii. Do not operate your scooter in sand, loose soil or over rough terrain. Doing so may damage wheels, bearings, axles or motors, or loosen fasteners.

C. STREET USE WARNING: In most states, scooters are not legal for use on public roads. Be alert to the danger of motor vehicles on roads or in parking lots.

- i. At night, or when it is hard to see, use reflective tape on your scooter and clothing.
- ii. It may be hard for drivers to see you. Make eye contact with drivers before you proceed. When in doubt, yield until you are sure it is safe.

D. MOTOR VEHICLE SAFETY

- i. Never sit in this scooter while in a moving vehicle. In an accident or sudden stop you may be thrown from the scooter.
- ii. Always move to an approved vehicle seat. You must be secured with proper motor vehicle restraints.
- iii. Never transport this scooter in the front seat of a vehicle. It may shift and interfere with the driver.
- iv. Always secure this scooter so that it cannot roll or shift.

E. TRANSFERS WARNING: It is dangerous to transfer on your own.

It requires good balance and agility. Be aware that there is a point during every transfer when the seat is not below you.

To avoid a fall:

- i. Always turn off power before you transfer to or from your scooter. If you fail to do so you may touch the throttle control lever and cause your scooter to move when you do not expect it.
- ii. Make sure scooter is turned "Off". This keeps the scooter from moving when you transfer.
- iii. Move your scooter as close as you can to the seat you are transferring to.
- iv. Transfer as far back onto the seat surface as you can. This will reduce the risk that you will miss the seat or fall.

F. REACHING OR LEANING WARNING: Reaching or leaning affects the center of balance of your scooter. If done improperly, a fall or tip-over is likely. When in doubt, ask for help or use a scooter to extend your reach.

To reduce the risk of injury and/or damage to the scooter:

- i. Never reach or lean if you must shift your weight sideways or rise up off the seat.
- ii. Never reach or lean if you must move forward in your seat to do so. Always keep your buttocks in contact with the backrest.
- iii. Never try to pick up an object from the floor by reaching down between your knees.
- iv. Never reach or lean over the top of the seat back. This may damage the backrest and cause you to fall. If you must reach or lean; do so at your own risk. Remember to:

ELECTROMAGNETIC INTERFERENCE



It is very important that you read this information regarding the possible effects of Electromagnetic Interference on your Supascoota.

This motorized scooter has an immunity of 20 V/m which should protect it from Electromagnetic Interference (EMI) from Radio Wave Sources. These EM waves are invisible and their strength increases as one approaches the source. All electrical conductors act as antennas to the EM signals and to varying degrees, all power wheelchairs and scooters are susceptible to electromagnetic interference (EMI). This interference could result in abnormal, unintentional movement and/or erratic control of the vehicle.

Motorized scooters may be susceptible to electromagnetic interference (EMI), which is interfering electromagnetic energy (EM) emitted from sources such as radio stations, TV stations, amateur radio (HAM) transmitters, two-way radios, and cellular phones. The interference (from radio wave sources) can cause the motorized scooter to release its brakes, move by itself, or move in unintended directions. It can also permanently damage the motorized scooter control system. The intensity of the interfering EM energy can be measured in volts per meter (V/m). Each motorized scooter can resist EMI up to certain intensity. This is called its "immunity level." The higher the immunity level, the greater the protection. At this time, current technology is capable of achieving at least a 20 V/m immunity level, which would provide useful protection from the more common sources of radiated EMI.

Because EM energy rapidly becomes more intense as one moves closer to the transmitting antenna (source), the EM fields from hand-held radio wave sources (transceivers) are of special concern. It is possible to unintentionally bring high levels of EM energy very close to the motorized scooter control system while using these devices. Therefore, the warnings listed below are recommended to prevent possible interference with the control system of the motorized scooter, which should reduce the chance of unintended brake release or motorized scooter movement that could result in serious injury.

- i. Move your scooter as close as you can to the object you wish to reach.
- ii. Turn off all power to your scooter. If you fail to do so, you may touch the throttle control lever and cause your scooter to move when you do not expect it.

G. DRIVING IN REVERSE WARNING: Use extra care when you drive your scooter in reverse. You may lose control or fall if one of the rear wheels hits an object.

- i. Operate your scooter slowly and at an even speed.
- ii. Stop often and check to make sure your path is clear of obstacles.

H. WEIGHT LIMIT

- i. Never exceed the weight limit of the scooter.
- ii. The scooter is not designed for weight training and is unsafe for use as a seat while weight training. Weight training from the scooter substantially changes the stability of the scooter and may cause tipping.
- iii. Exceeding the weight limit is likely to damage the seat, frame or fasteners and may cause severe injury to you or others from scooter failure.

I. STAIRWAYS AND ESCALATORS WARNING:

The scooter is not designed to travel up or down stairs or escalators. Always use an elevator. **DO NOT** use an escalator to move the scooter between floors. Serious bodily injury may occur. **DO NOT** attempt to move an occupied scooter between floors using a stairway.



WARNING Do not operate hand-held personal communication devices such as citizens band (CB) radios, or turn ON personal communication devices and cellular phones while the motorized scooter is turned ON.

- 1) Be aware of nearby transmitters, such as radio or TV stations and try to avoid coming close to them.
- 2) If unintended movement or brake release occurs, turn the motorized scooter OFF as soon as it is safe.
- 3) Be aware that adding accessories or components, or modifying the motorized scooter, may make it more susceptible to EMI; and **NOTE: There is no easy way to evaluate their effect on the overall immunity of the motorized scooter.**
- 4) Report all incidents of unintended movement or brake release to the distributor listed on the back of this manual, and **Note whether there is a radio wave source of EMI nearby.**

TURN “OFF” YOUR SCOOTER AS SOON AS POSSIBLE WHEN EXPERIENCING THE FOLLOWING:

- Unintended or uncontrollable movement.
- Unexpected brake release

• Important Information

- 1) 20 Volts per meter (V/m) is a generally achievable and useful immunity level against interference from radio wave sources (as of May 1994) (the higher the level, the greater the protection);
- 2) This product has an immunity level of following:

Guidance and MANUFACTURER’S declaration – electromagnetic IMMUNITY – for all ME EQUIPMENT and ME SYSTEMS

Guidance and manufacturer’s declaration – electromagnetic immunity			
The [ME EQUIPMENT or ME SYSTEM] is intended for use in the electromagnetic environment specified below. The customer or the user of the [ME EQUIPMENT or ME SYSTEM] should assure that it is used in such an environment.			
IMMUNITY test	IEC 60601 test level	Compliance level	Electromagnetic environment – guidance
Electrostatic discharge (ESD) IEC 61000-4-2	± 6 kV contact ± 8 kV air	± 6 kV contact ± 8 kV air	Floors should be wood, concrete or ceramic tile. If floors are covered with synthetic material, the relative humidity should be at least 30 %.
Electrical fast transient/burst IEC 61000-4-4	± 2 kV for power supply lines ± 1 kV for input/output lines	± 2 kV for power supply lines ± 1 kV for input/output lines	Mains power quality should be that of a typical commercial or hospital environment.
Surge IEC 61000-4-5	± 1 kV line(s) to line(s) ± 2 kV line(s) to earth	± 1 kV line(s) to line(s) ± 2 kV line(s) to earth	Mains power quality should be that of a typical commercial or hospital environment.
Voltage dips, short interruptions and voltage variations on power supply input lines IEC 61000-4-11	<5 % U_T (>95 % dip in U_T) for 0,5 cycle 40 % U_T (60 % dip in U_T) for 5 cycles 70 % U_T (30 % dip in U_T) for 25 cycles <5 % U_T (>95 % dip in U_T) for 5 s	<5 % U_T (>95 % dip in U_T) for 0,5 cycle 40 % U_T (60 % dip in U_T) for 5 cycles 70 % U_T (30 % dip in U_T) for 25 cycles <5 % U_T (>95 % dip in U_T) for 5 s	Mains power quality should be that of a typical commercial or hospital environment. If the user of the [ME EQUIPMENT or ME SYSTEM] requires continued operation during power mains interruptions, it is recommended that the [ME EQUIPMENT or ME SYSTEM] be powered from an uninterruptible power supply or a battery.
Power frequency (50/60 Hz) magnetic field IEC 61000-4-8	3 A/m	3 A/m	Power frequency magnetic fields should be at levels characteristic of a typical location in a typical commercial or hospital environment.
NOTE U_T is the a.c. mains voltage prior to application of the test level.			

ASSEMBLE THE SEAT

Assemble the seat frame in the manner illustrated.

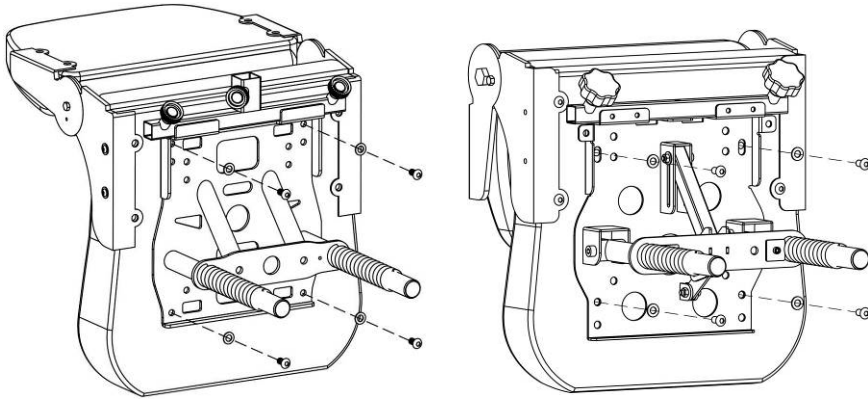

FOLDABLE SEAT FRAME - OPTIONAL

To open the seat frame

Pull out the knob "Z" in the direction of the arrow and lift the seat tube "C" up as illustrated.

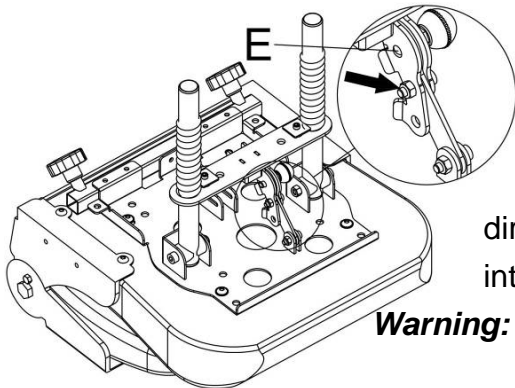
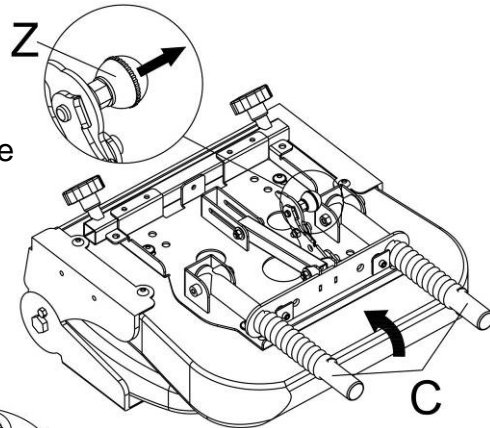

Push the support lever in the direction of the arrow until it clicks into position "E".

Warning: Pin "E" must be locked into the position before using.

To fold the seat frame

Pull out the knob "Z" in the direction of the arrow and push D downward as arrow illustrated then push seat tube "C" downward to fold the seat frame.

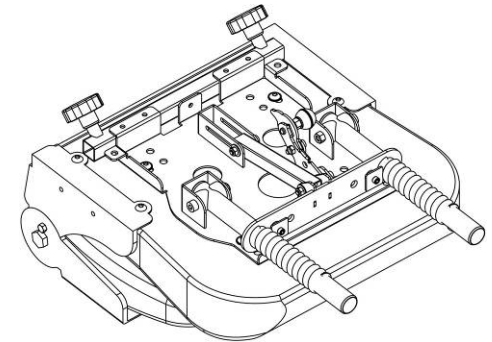
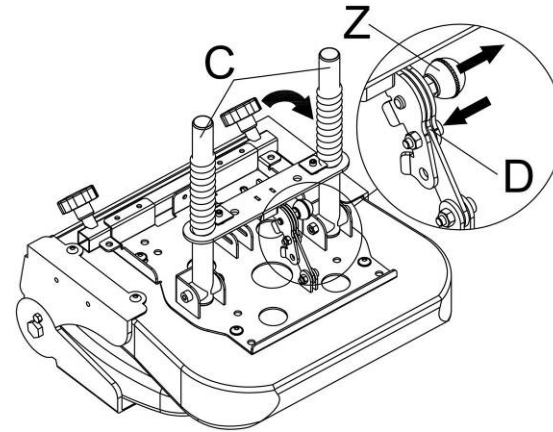

WARNING !
Pull to lock before sitting.

CAUTION

The armrests on your SupaScoota are not designed to be load bearing.
DO NOT PUT EXCESSIVE WEIGHT ON THE ARMRESTS

TO OPEN THE SUPASCOOTA

- Use one hand to hold the tiller handle (D) and use the other hand to push the lock pin lever per the illustration and lift the handle. Pull the tiller lock (C) and turn it clockwise. Continue lifting the tiller until you hear the “click”, the locking into position.

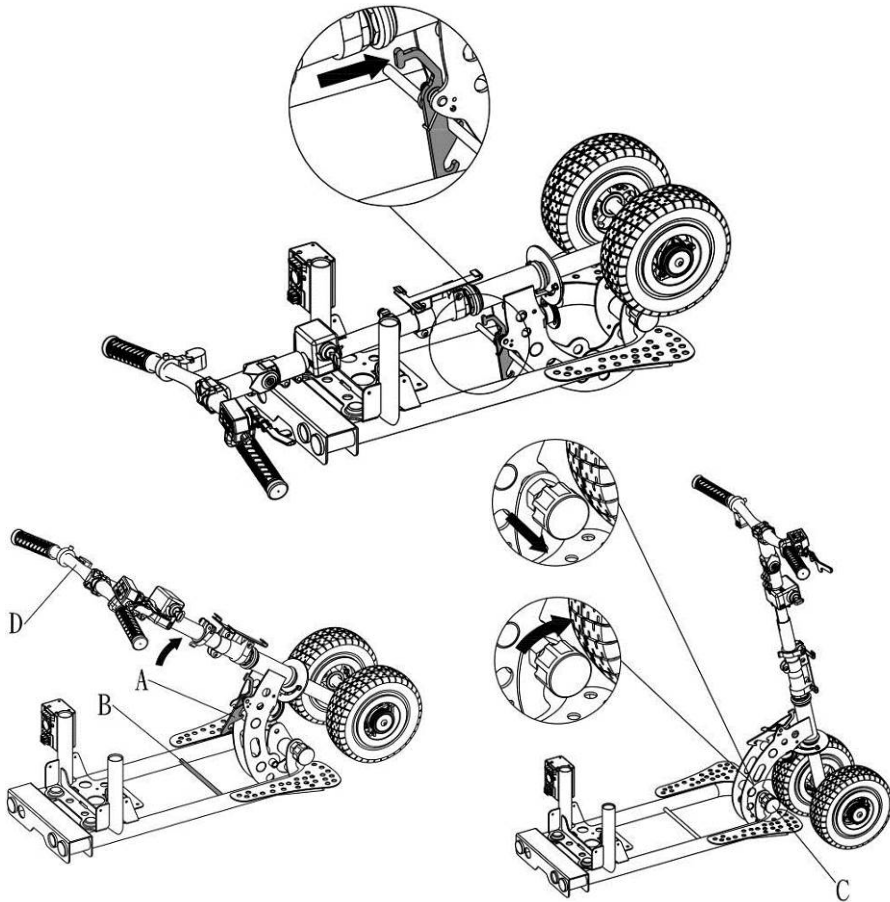

Frame Assembly

Assembly and disassembly is best carried out by pulling the locking pin C and allowing the tiller assembly to fold forward until it rests on the ground.

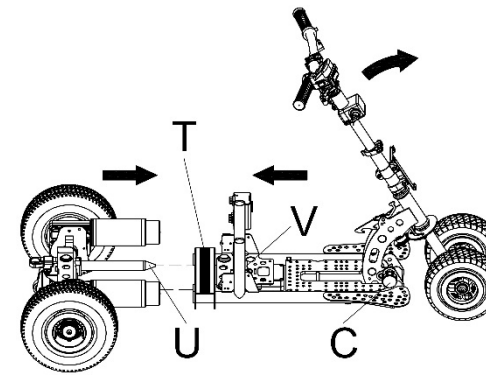

- Pull the lock pin knob (V) and turn it to the “lock” position.
- Hold both frame sections horizontally by using the strap (T) with one hand and the rear section with the other hand and slide both together by inserting the tubes (U) into the corresponding holes in the front frame.
- The pin will click when inserted correctly. **You must check that the pin has locked into position.**

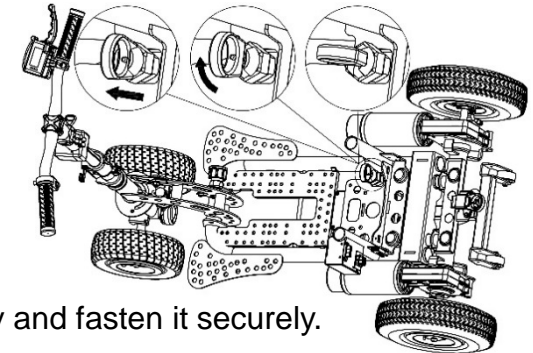

For SLA Battery

- Install the battery into the tray and fasten it securely.

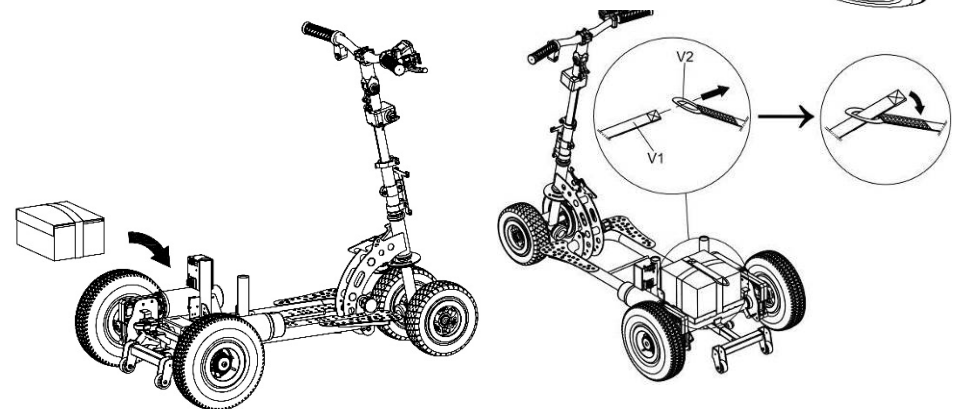

For Lithium Battery

- Pull the knob (C) backward and have 2 block (A) Insert into slots (B) as illustrated direction then push battery module downward until you hear click sound, the locking into cam locker.
- **You must check that the battery module has locked into position.**

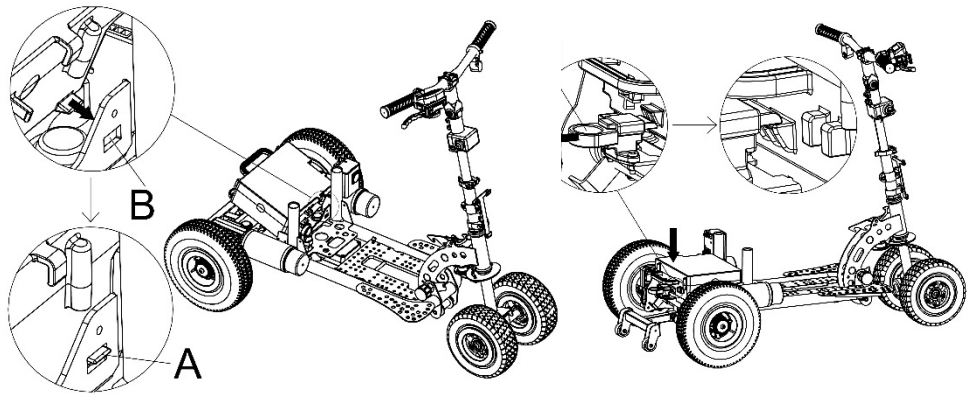

- Reconnect plugs.
- Plug the main connector "T" into "M" on the frame.
- Plug in the battery connector "L1" into "L2" on the frame.
- The connectors are color matched. Don't try to force it into the wrong position.

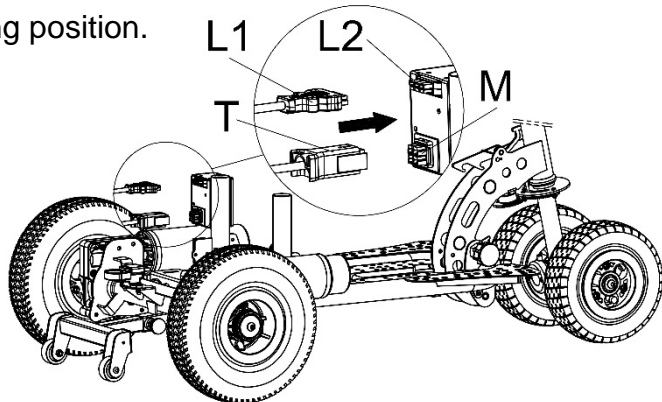

- Fit the seat on to the frame and insert the seat frame tubes into the corresponding holes on the main frame.

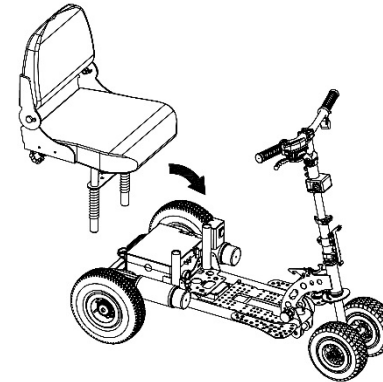

- Insert arm rest per the illustration.

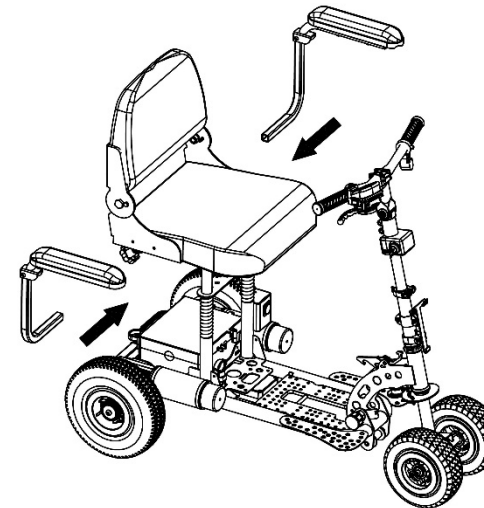

- Tighten the screws

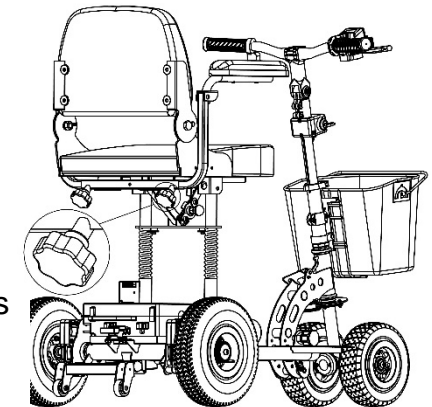
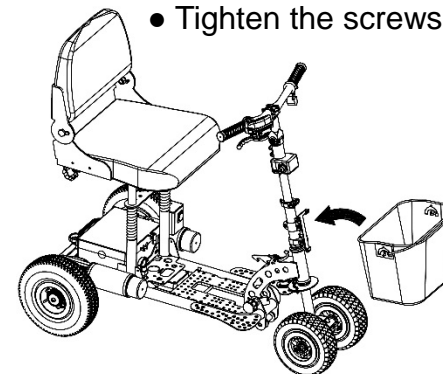

- Fit the front basket

WARNING

- Owners manual must be read before using.
- Always ensure that the scooter is powered off before getting on or off.
- Do not exceed inclines more than 8 deg.
- Check tire pressure regularly 30-40 PSI.
- Speed must be reduced when turning.
- Recharge battery after every use.
- Always keep feet on footplates when using scooter.

WARNING !
Extend anti-tip wheels
before using scooter.

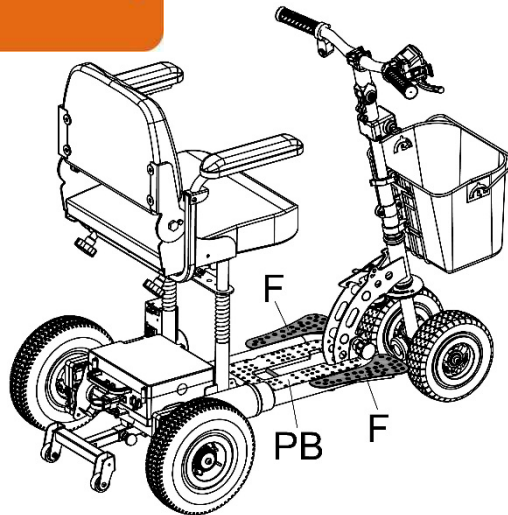

- Inflate the tyres to the maximum of 40 PSI.

CAUTION

The partition board (PB) on your Supascoota is not designed to load bearing, have your feet always stay on the footrest (F) per indicated above.

DO NOT PUT EXCESSIVE WEIGHT ON THE PARTITION BOARD.

WARNING

IT IS IMPORTANT THAT YOU TAKE EXTRA CARE TO PRACTICE IN AN OPEN SPACE AWAY FROM OBSTRUCTIONS.

ANTI-TIP WHEEL

WARNING

Ensure that the anti-tip wheels are extended and locked in the position "Q" when driving on sloping ground. (Per illustration below)

To change the locking position, just pull the knob "Q" and slide the tube to the preferred position. Position "Q" provides the greatest stability. Return the sliding tube to position "P" for transportation or disassembly.

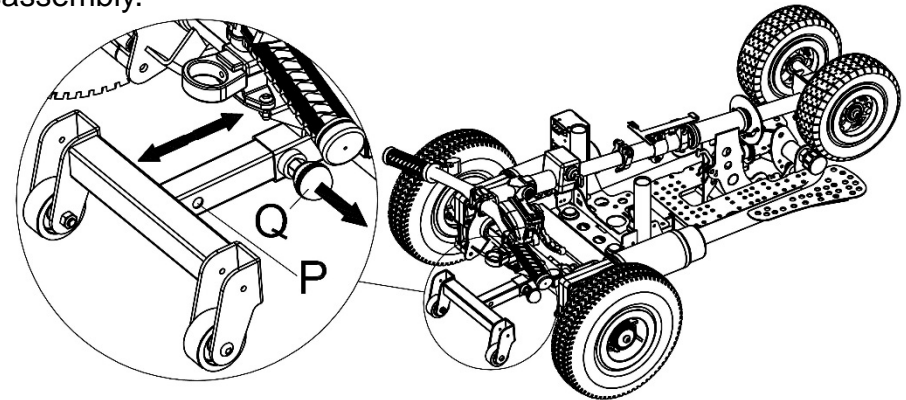

WARNING !
To prevent the scooter from tipping backwards the anti-tip frame must be locked in the maximum extended position.

CAUTION

- Do not turn key switch "On" before you are seated ready to go.
- Always turn the key switch "Off" before getting off the scooter.

NOTE: Please be aware that should the scooter wheels meet an obstruction, you will need to help it out manually. Attempting to drive through an obstruction when the wheel is stuck could result in damage

DRIVE WHEEL RELEASE MECHANISM

- This scooter is equipped with drive wheel release mechanism. Your SupaScoota can be moved manually after the drive wheels are released.



Do not operate this device on slope.

To disengage the drive wheels
Pull the drive collar (part "A") out and turn it left or right, then release it.

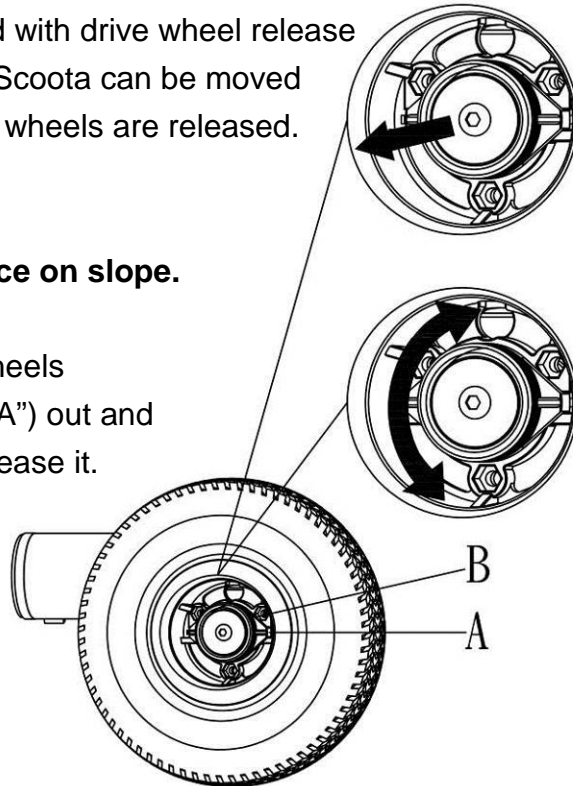

To reconnect the drive wheels

Turn the drive collar (part "A") until it reconnects with the wheel and then move the scooter until the collar connects with the drive. (a loud click)

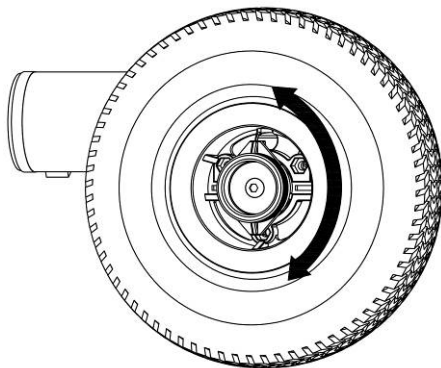

CRUISE CONTROL, LIGHTS AND SWITCHES

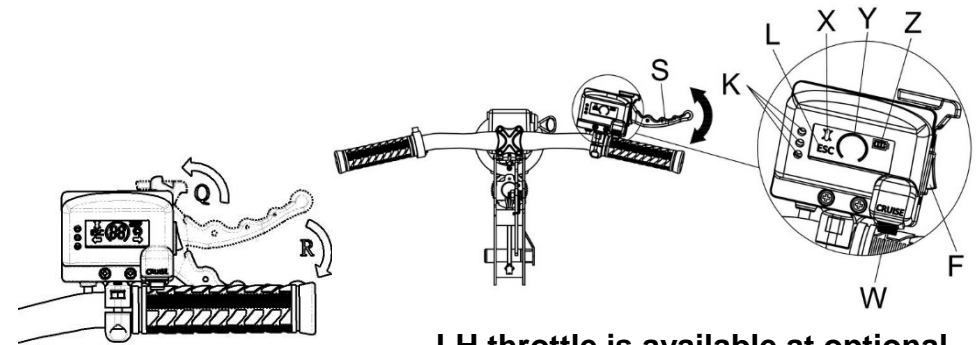

LH throttle is available at optional

To lock the speed lever for transportation:

CAUTION ! : ONLY BE USED WHEN POWER is OFF.

Pull the lever as arrow direction "R" and use the other hand to turn the locker as arrow direction "Q"

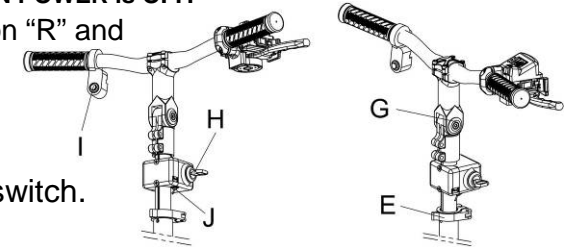

- F : Forward and Reverse switch.
- S : Speed lever.
- K : Battery level indicator. (for lead-acid battery)
- H : Key switch
- J : Speed selection: F / full speed, S / reduced speed
- I : Disable button for ESC
- X: Disable ESC indicator
- W: Cruise activate & deactivate button
- Y: Cruise control indicator
- E : Clamp for height adjustment
- G: Handle bar angle adjustment
- Z : Battery green level gauge

Please note the display of the three green levels (Z) varies from different scooter models, battery sizes as well as the terrains conditions.



Do not place your fingers on the speed lever before you turn the key switch "On".

Do not operate speed selection switch "J" when scooter is moving. Pull the speed lever "S" and accelerate slowly. Do not pull speed lever "S" in rapid operation.

CRUISE CONTROL- OPTIONAL

When Cruise control is activated, the scooter automatically maintains the stored speed.

To use cruise control:

You can operate cruise control at variable speed with pushing cruise button “W” and the indicator “Y” will be light on.

To deactivate cruise control:

Briefly push cruise control button “W” or pull down the speed lever “S” then release immediately.



- **Use cruise control only if road and traffic conditions make it appropriate to maintain a steady speed for prolonged period.**
- Always pay attention to traffic conditions even when cruise control is activated.
- Cruise control is only an aid designed to assist driving. You are responsible for the scooter’s speed and brake in good time.



Do not use cruise control:

- In traffic conditions which are not allowed you to drive at a constant speed, e.g. heavy traffic, winding or bumpy roads, where may cause an accident.
- On slippery roads, the drive wheels may lose their grip when braking or accelerating which may cause the scooter to skid.
- When there is low visibility, e.g. due to fog, heavy rain or snow.
- Cruise control may be unable to maintain the stored speed on uphill gradients. Hence, do not use cruise control when slope is of or over 4 degrees.
- Do not use cruise control when riding downhill.

If the scooter does not move after the re-set, one of the following indicator lights may be displayed:

Green light flashes quickly	The magnetic brake either turn off or connectors are loose.
Green light flashes slowly	Batteries on scooter for recharging with the key switch turn on.
Yellow & Red light ON	Low voltage of batteries detected by controller
Green, Red & Yellow light ON	Potentiometer broken down.
Red & Green lights flash alternately	Overload protection.
Red light ON	Battery needs recharging or connection faulty - check grey color connector.
Yellow light flashes quickly	Unusual current output.

AUTO SWITCH OFF ELECTRONIC SYSTEM

- The electronic system of this scooter is protected by a digital over current cut-off system. If your SupaScoota stops, you will need to turn the main key switch to the “Off” position, and then switch to “On” position to reset the system.
- Possible causes of over current cut-out are battery not fully charged or near the end of its life, or the slope is too steep for the scooter. Do not continue to overload the system as this may damage the controller.
- The electronic system of this scooter will switch itself “Off” after 3 minutes if the key switch is left in the “On” position when the scooter is not in use. You will then need to turn the key switch to the “Off” position, and then switch to “On” position to reset the control system.

ELECTRONIC STABILITY CONTROL (ESC)

This is the most significant advancement in mobility scooter safety ever designed and has dramatically reduced accidents due to operator misuse. Turning corners at excessive speed has always been one of the most common causes of accidents but with clever engineering and sophisticated electronics we have all but eliminated this problem. The speed of the SupaScoota is now electronically governed in direct proportion to the rotation of the handle bars, virtually eliminating any possibility of over speeding when turning. With the handle bars at maximum rotation and the throttle at maximum speed the scooter will turn at a very low speed with complete safety. No other scooter can provide this level of safety. Some situations may require maximum power to be used when turning and we have allowed for this with a handlebar mounted push button which will disable the ESC for 20 seconds if needed. (Push button for one second)



⚠ WARNING

Keep fingers and clothing away from the Electronic Stability Control sensor.

This vital piece of equipment is very sensitive and could be damaged, or could cause damage, if tampered with.

Warning. If the ESC is disconnected or faulty, the scooter will continue to function normally **but the speed will not reduce when turning.**

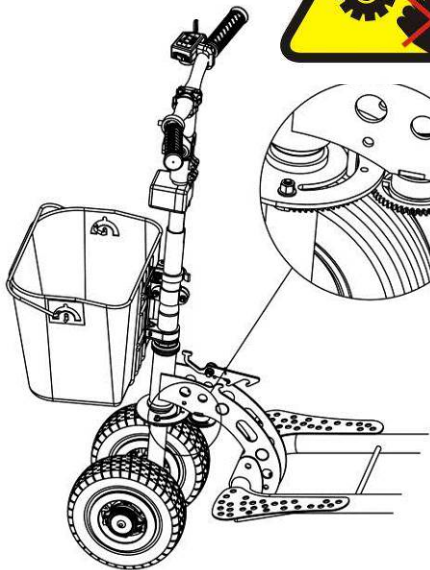

SWIVEL SEAT (OPTIONAL)

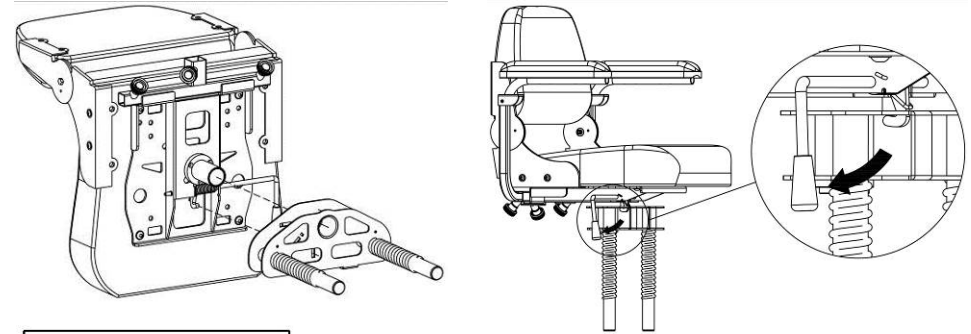

⚠ CAUTION

When removing the seat, do not lift the release handle as this could cause the seat support frame to disconnect from the seat and fall.

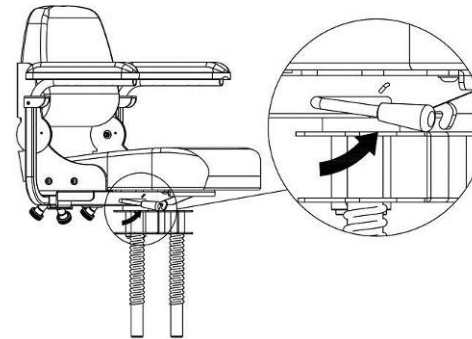

To turn the seat, lift and hold the release handle below the seat (as shown). This will allow the seat to turn.

SPARE BATTERY TRAY (OPTIONAL)

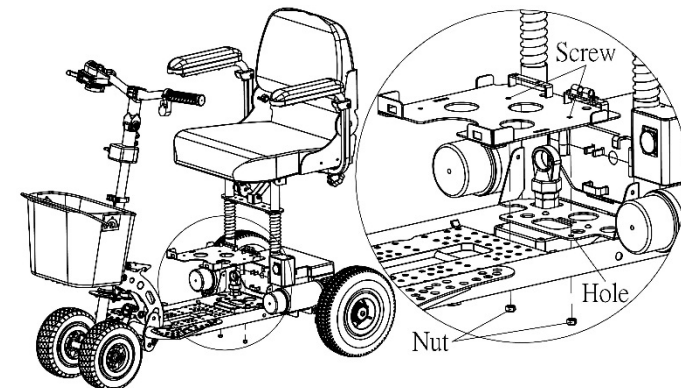

Assemble the battery tray as illustrated. Insert the screws and tighten the nuts. When using a lithium battery it is recommended that you place your lithium battery on rear tray of the scooter and your SLA battery on the front tray.

It is also recommended that you use the lithium battery and keep the SLA battery in reserve.

SPARE LITHIUM BATTERY

Optional

Assemble the locker "E" to the position "D" as illustrated.

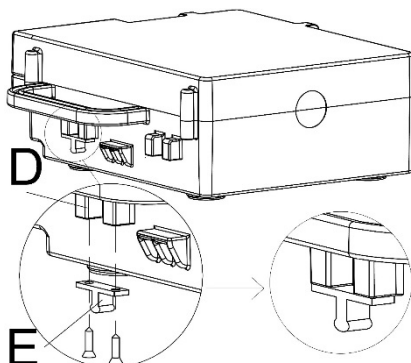

- To have spare battery seated onto spare tray, have 2 block (F) Insert into slots (G) as illustrated direction then push battery module downward.

- **You must check that the battery module has locked into position.**

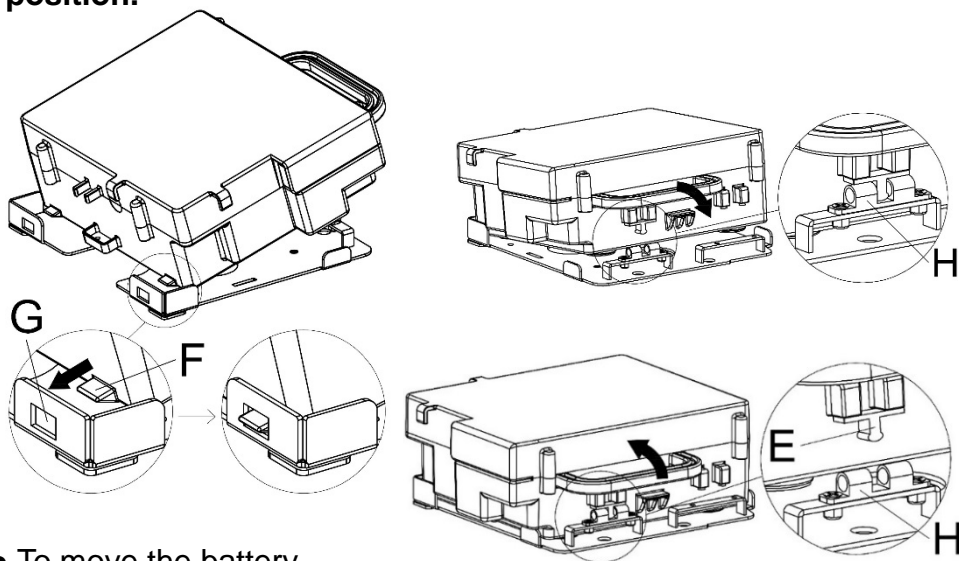

- To move the battery just pull up and move away.

SWITCH THE BATTERY TYPE

This scooter can be used either SLA or lithium battery. To meet the right voltage to the battery gauge, it is allowed to set by following step to select the different types of battery for going to use.

- Have the key switch at OFF position, keep pressing the ESC button "I" and turning the key to switch on, then releasing ESC button.
- Turn the FWD / REV switch "F" to select the battery type you are going to use. (The led light of "K" must be at off position)
- Li = lithium battery, SA = lead-acid battery

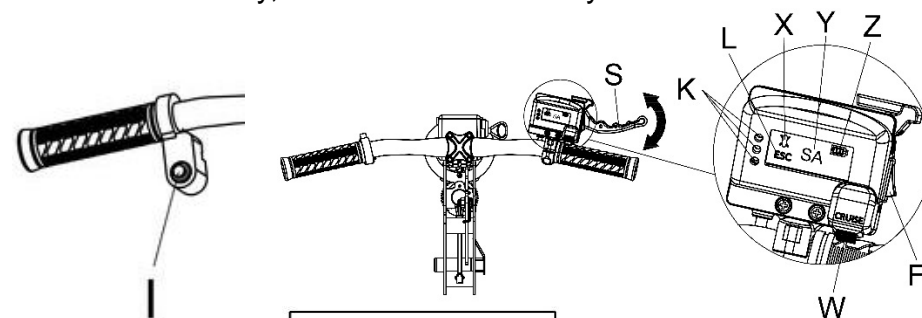

IMPORTANT NOTE:  CAUTION

The stored program only meets the specification of manufacturer's battery.

Do not use any battery (include lithium) & Charger which are NOT specified by manufacturer.

FRONT WHEEL REMOVAL (OPTIONAL)

To reduce weight when lifting the scooter

The front wheels of the scooter can be quickly removed when it is in the folded position by pushing the release pin "J" and pull front wheels out as per the illustration. This will reduce the weight by approximately 2 kg

Reassemble in the reverse order.



WARNING Double check that the shaft "K" is locked in position before unfolding the frame and using the scooter.

If it is unstable during using, you must stop the scooter and check to see if shaft "K" is loosen.

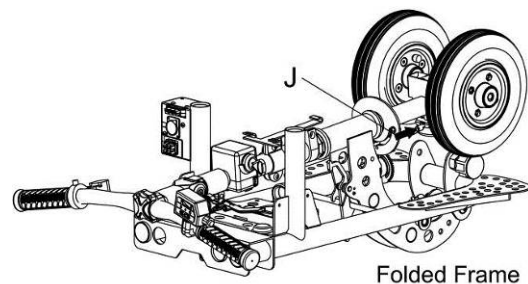
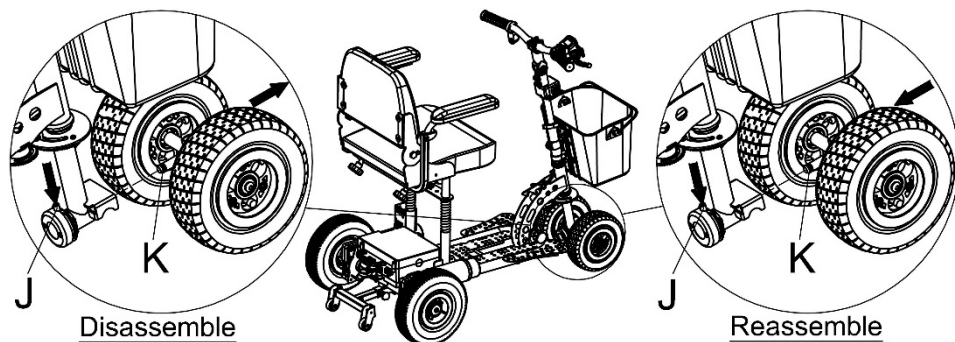

WARNING !
Axle must be securely locked in position after assembling front wheels. (Refer to user manual)

HOW TO CLEAN THE SCOOTER

Avoid power spray water washing of the scooter as this could cause damage to the wire connectors and electronic system.

Completely dry off the scooter, if necessary use a dry cloth after cleaning your scooter.

PRECAUTION

- When using your scooter for the first time you should practice at slow speed in a flat open area free of obstacles, until you are confident in turning, stopping, reversing and judging braking distance.
- This scooter is designed for the maximum rider weight of 125kgs.
- Always switch power off (Key switch to "Off" position) before leaving your scooter.
- Do not store your scooter outside without adequate protection.
- Keep the shipping carton in dry place after unpacking your SupaScoota in case it needs to be shipped for service.
- This appliance is not intended for use by persons (including children) with insufficiency of physical, sensory or mental capabilities, or lack of experience and knowledge, unless they have been given instructions concerning use of the appliance by a person responsible for their safety. Children should be supervised to ensure that they do not play with the appliance.



WARNING
Your SupaScoota is extremely maneuverable but sharp turns must only be done at very slow speed.



CAUTION
Do not operate the Forward/Reverse switch when scooter moving. This could damage your SupaScoota.

FOLD THE SUPASCOOTA

- Release screws and then remove the arm rests from scooter.

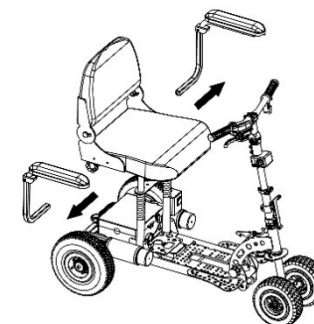
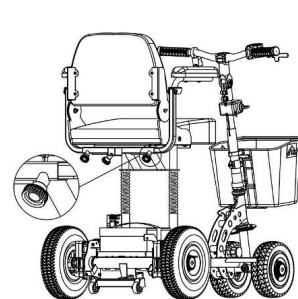

- Remove front baskets from scooter.

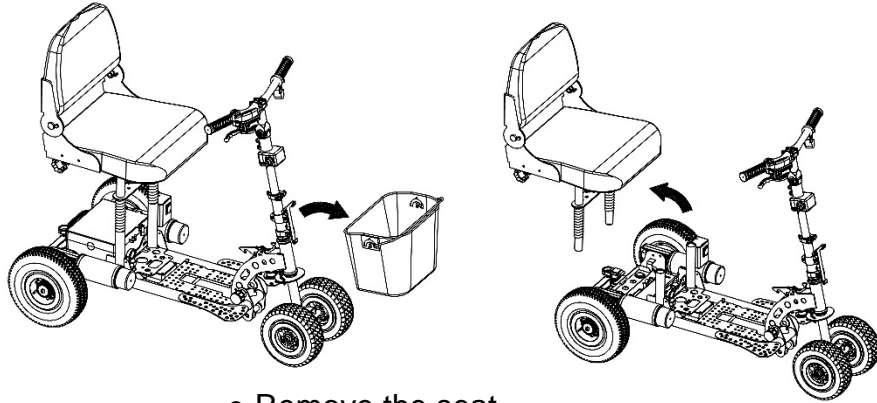

- Remove the seat.

For SLA Battery

- Unplug the battery connector, undo the strap and remove the SLA battery.

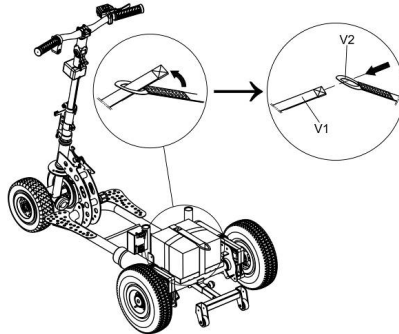

For Lithium Battery

- Unplug the battery connector, pull knob backward and pull up the battery handle for removing lithium battery as illustrated.

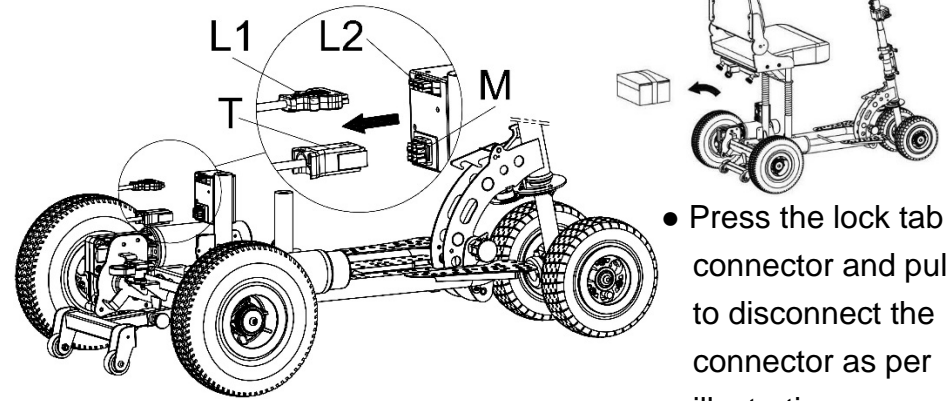
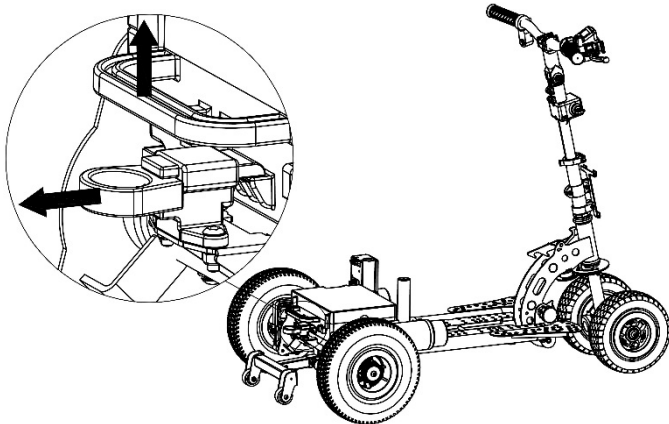

- Press the lock tab of connector and pull out to disconnect the connector as per illustration.

Frame Disassembly

Disassembly is best carried out by pulling the locking pin C and allowing the tiller assembly to fold as arrow direction until it rests on the ground.

- Unplug all connectors.
- Pull the lock pin knob (V) and turn it to the “unlock” position, pull lock pin (C) and lower the tiller until the frame rests on the ground.
- Hold the strap (T) with one hand and the rear section of the scooter frame with the other hand and slide the 2 halves of the frame apart.

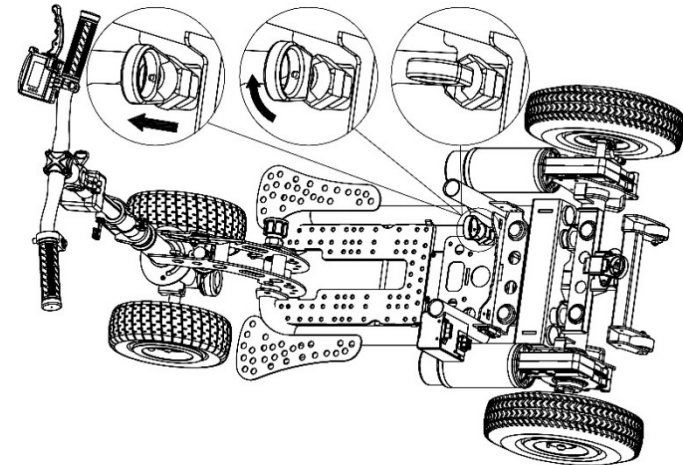

CHARGE BATTERY

- When you get your new battery put it on charge for at least 24 hours.
- When recharging your battery, always charge for at least 12 hours or until the light on the charger turns green. It is best to charge for at least another hour after the light turns green.
- Never use the battery for any purpose except to power your scooter.
- The battery charger can become hot during charging so your charger should be placed in a suitable place with good air flow and away from children.

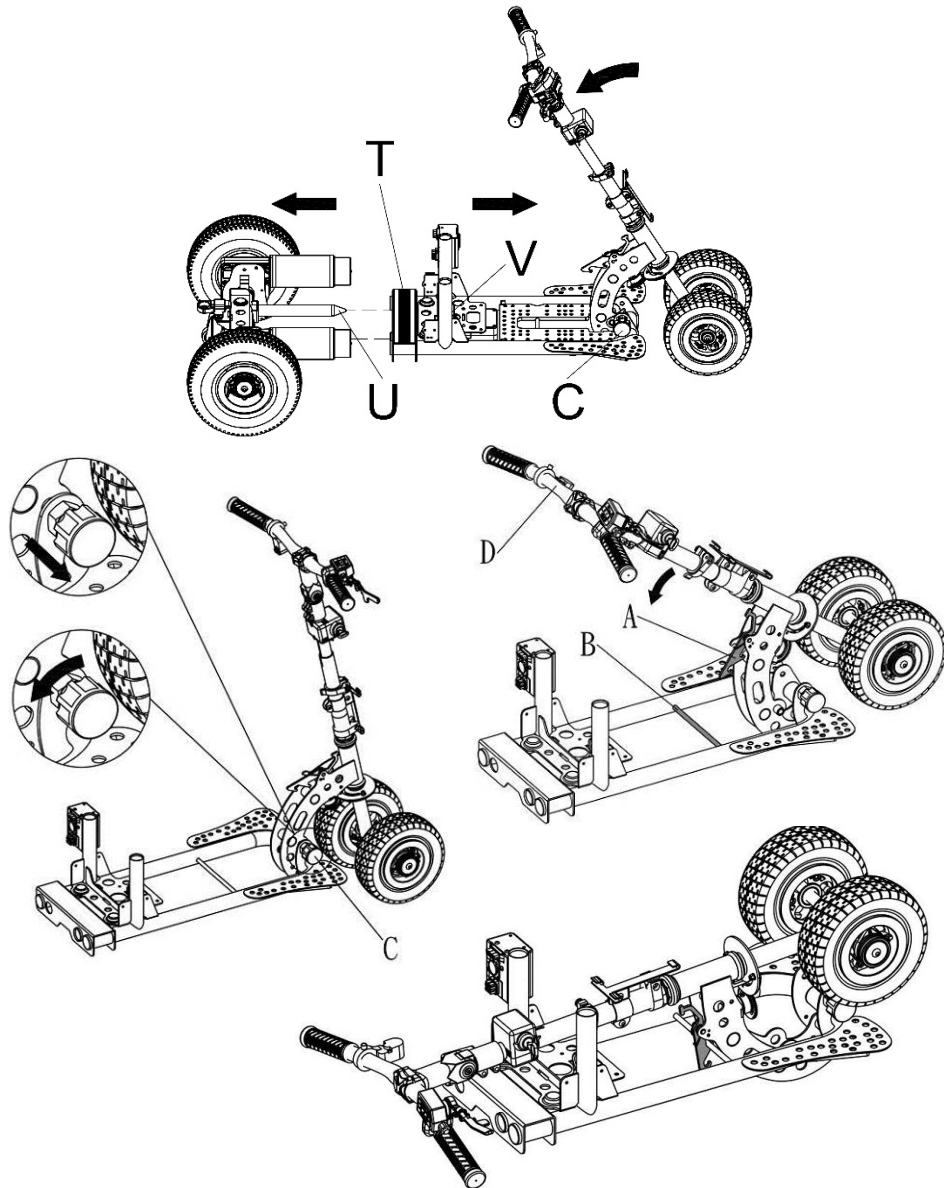

- Use one hand to hold the handle, and use the other hand to pull the lock pin knob (C) and turn it anticlockwise. Then fold the handle down until you hear the “click” of the locking pin fitting into position on the main frame.

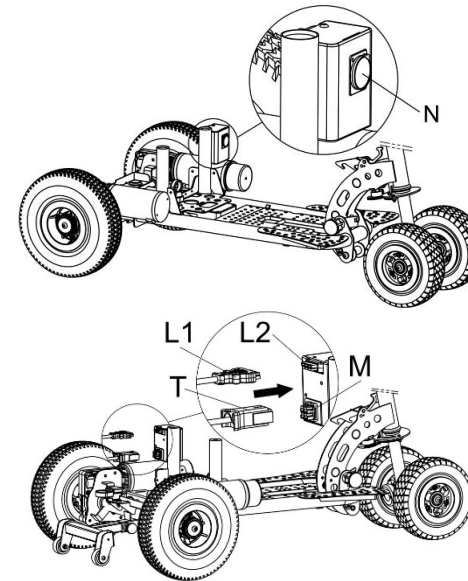

To recharge the batteries, follow the steps below:

- Place your Scooter close to a standard electrical wall outlet.
- Turn the scooter key switch to the “Off” position.
- Plug the charger power cord (Round plug) into the socket indicated on scooter. (N)
- Plug the charger power plug into a standard wall outlet.
- When charging is completed, the yellow LED will turn to green.
- Disconnect the charger power cord from the wall outlet and the plug from the scooter when the batteries are fully charged.
- NOTE: The battery connector L1 must be connected to L2 for charging.

Or remove the battery from scooter, and use the connection adaptor. (Optional accessory)

Do not place the battery on a concrete floor for charging. Raise the battery off the concrete with wooden blocks or similar objects.



IMPORTANT NOTICE:

The battery terminal covers must be kept in place at all times to avoid the possibility of something falling across the terminals and causing a short circuit. This could damage the battery or even cause it to explode.

To dispose of your battery, return it to your dealer or to a recycler. Improper disposal of the battery could result in an explosion causing injury and/or property damage.

Lithium battery & charger are optional accessories.

Do not use any battery (include lithium) which is NOT specified by manufacturer.

Travel distance from battery indicator & Cycles life

Items Battery Type	Green light	Yellow light	Red light	Cycle life (battery's)
24V 15ah SLA Battery	9 Km (5.6 miles)	2.0 Km (1.2 miles)		400
24V 15ah Lithium Battery	13 Km (8 miles)	2.5 Km (1.5 mile)		1000
24V 12ah Lithium Battery	8 Km (5 miles)	3 Km (1.9 miles)		800

Above are based on full charged battery with firm & even road surfaces condition and can be varied from cycles by using which may effected from duration reduced of riding distance per charge. When the Yellow light is "On", you will need to go for recharging the battery and do not use scooter when Red light is ON.

BATTERY CHARGER



- Before charging, read the instructions. (included with charger)
- For indoor use only, do not expose to rain.
- Disconnect the mains power supply before making or breaking the connections to the battery.
- This appliance is not intended for use by persons (including children) with reduced of physical, sensory or mental capabilities, or lack of experience and knowledge, unless they have been given instructions concerning use of the appliance by a person responsible for their safety. Children should be supervised to ensure that they do not play with the appliance.
- This charger is not for recharging non-rechargeable batteries.
- Do not use for charging any batteries not specified by the manufacturer.

BATTERY CARE & MAINTENANCE



Important notes to help prolong the life of the battery:

- Before the first use of your battery, put it on charge for 24 hours.
- Do not place the battery on a concrete floor for charging, have the battery raised off the floor on wooden blocks or place the battery on a shelf. (when moving the batteries out of scooter for recharging)
- To fully charge the battery, choose a place where ambient temperature is above 10 degrees Celsius.
- Always recharge your battery as soon as possible after use.
- When yellow light is "On" you should recharge your battery as soon as possible.
- Never use the battery when the red light is "On". You will discharge the battery below its designated voltage and damage it.
- Do not drop the battery.
- **STORAGE:**
If you know that you will not be using your battery in the near future, disconnect the battery from the charger and store it in a suitable dry place.
Recharge your battery before you use it or **every 3 months (No more than 3 months) if it is not used in that period.**
- Always contact our service agent before you replace the battery or the charger. Using an incompatible battery or charger may damage the scooter and void your warranty.

NOTE: The battery gauge on the scooter does not give accurate readings when using a lithium battery, unless reselect for meet the right voltage. (P.25)

SLA BATTERY WIRING DIAGRAM

WARNING:

The battery leads must be connected to the correct battery terminals. Connect battery lead per illustration.

- **SLA battery**15ah
2 x 12V 15ah

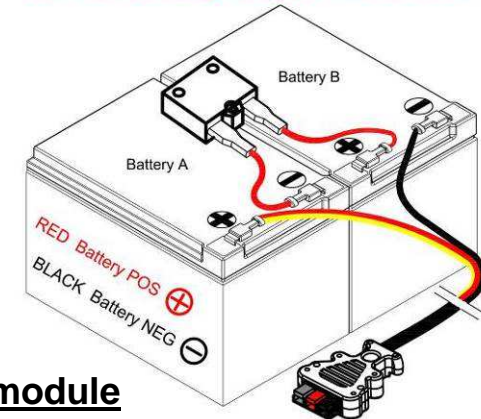

- **Lithium battery module**
25.6V 15ah & 25.6V 12ah



This lithium battery module has individual user's manual. Read before use.

Specifications

Front Wheel Size	200mm (8")
Rear Wheel Size	260mm (10")
Ground Clearance(tiller)	65mm (2.6")
Length	SPHD-1050mm (41.3")
Width	600mm (23.6")
Weight Without Seat	SPHD-21.9 kg (48 lbs)
Front Frame Weight	Front Frame :10.9 kg (24 lbs) Front Frame Without Front Wheel:8.7 kg (19 lbs)
Rear Frame Weight	SPHD-11.1 kg(24.5 lbs)
Weight of Seat	8.6 kgs(19 lbs included seat frame & armrest) 11.5 kgs (25 lbs included swivel seat & armrest)
Max Loading	SPHD:110kg (242 lbs) on level ground
Turn Radius	SPHD-915mm (36")
Motor Output	2-150W (SPHD)
Transmission	Worm Drive Gearbox
Reverse	Forward/Reverse Switch
Brakes	Dynamic Braking and Electromagnetic Brake
Battery (SLA / Lithium)	SLA: 24V - 15 ah 9.2kg (20 lbs), / Lithium: 24V 12ah or 15ah / 3.2 kg (7 lbs) or 3.7 kg (8.1 lbs)
Charger (SLA/Lithium)	24 volt 2 amp / 24V 2 amp
Max Speed SLA Battery	8.8 kph (5.5 mph), 2 nd speed choice 5.1 kph (3.2 mph)
Max Speed SLA Battery (UK)	6.4 kph (4 mph), 2 nd speed choice 4 kph (2.5 mph)
Slope Grade Ability	Max. Recommended - 9 Degrees
Travel Distance	Up to 11.5 km (7.1 miles) with standard SLA battery, / up to 16 Km (9.9 miles) or 11.5km (7.1 miles) with 24V 15ah or 12ah lithium battery.
Arm Rests	Distance between armrests 45cm - 55cm (18 -22")

SupaScoota Warranty

Your SupaScoota is fully guaranteed against faults arising due to defects in manufacture or materials as follows

Frame: **2 years**.

The height adjustable tiller and all other components except those listed below: **1 year**.

Subject to availability of parts, any such defects will be rectified, either by repair or by unit replacement.

Warranty does not cover

Any damage due to improper use nor the replacement of parts arising from normal wear and tear such as potentiometers, tyres, arm rests and upholstery.

Claims due to a normal increase in operational noise level.

This warranty does not cover labour or service calls.

Batteries

Batteries are covered by a six month warranty from the original manufacturer. Gradual deterioration due to being left in a discharged state or being left in cold conditions for long periods is not covered.

This section **MUST BE READ** and **SIGNED** by the purchaser and stamped by the dealer

This warranty record must be kept by the purchaser and a copy supplied with any claim

I / we acknowledge that the SupaScoota has been delivered in good order and operating condition and that I / we have been instructed in the care and maintenance, safe operation and proper use of the unit.

Purchasers
name.....

Purchase date.....

Address

.....

Serial NoKey No.....

Signature.....

Stamp of Dealer

Date: